

# Original operating and assembly manual for grease lubrication pumps

## **EP-1** **FKGGM-EP** DC **FKGGM-EP** with power supply unit, AC 1

without control unit  
with integrated control units:  
BEKA-troniX1  
EP-tronic  
EP-tronic T1  
EP-T2

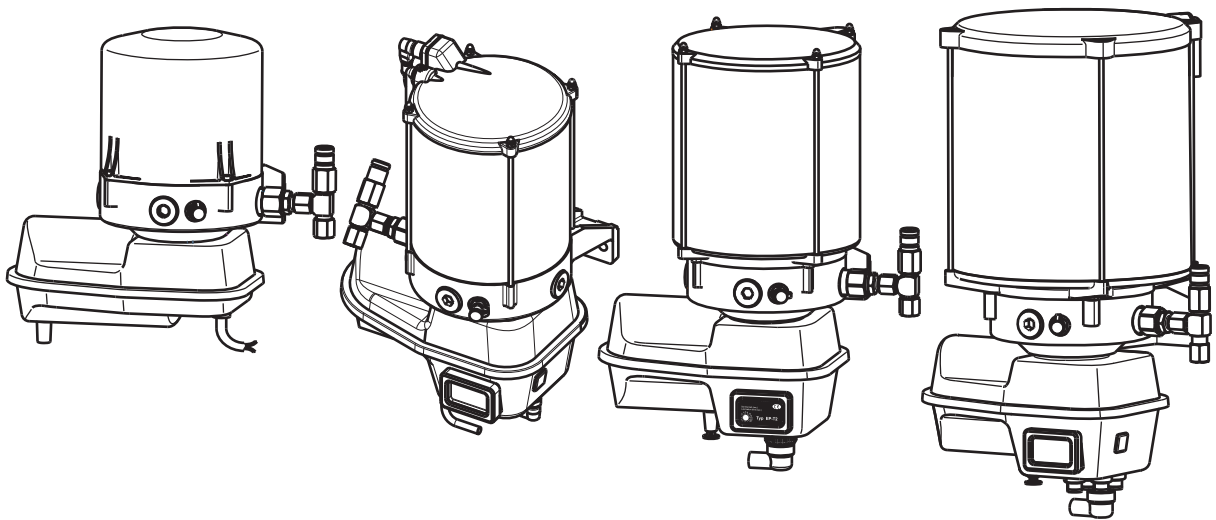

**EN**

## Contents

	Declaration of incorporation . . . . .	2+3
1.	Legend . . . . .	4
2.	Warranty and extent of warranty . . . . .	5
3.	Safety information . . . . .	5-8
4.	Technical data . . . . .	8+9
5.	Assembly manual. . . . .	10
6.	Overview and installation dimensions:	
6.1.	Central lubrication pump EP-1 and FKGGM-EP with steel reservoir. . . . .	10
6.2.	Central lubrication pump EP-1 and FKGGM-EP w. transpar. reservoir . . . . .	11+12
7.	Terminal diagrams:	
7.1.	Central lubrication pump EP-1 and FKGGM-EP without control unit. . . . .	13
7.2.	Central lubrication pump EP-1 without control unit Special model with bayonet connector . . . . .	13
7.3.	Central lubrication pump EP-1 and FKGGM-EP with integrated control unit BEKA-troniX1 . . . . .	14
7.4.	Central lubrication pump EP-1 with integrated control unit EP-tronic T1 . . . . .	12
7.5.	Central lubrication pump EP-1 with integrated control unit EP-T2 . . . . .	14
7.6.	Central lubrication pump EP-1 and FKGGM-EP with integrated control unit EP-tronic. . . . .	15
7.7.	Central lubrication pump FKGGM-EP with power supply unit . . . . .	16
8.	Function and design of the system . . . . .	16
9.	Function of the central lubrication pump:	
9.1.	Without control unit . . . . .	17
9.2.	With PE-120 V . . . . .	17
9.3.	Special equipment of the central lubrication pump without control unit:	
9.3.1	Grease level monitoring with plug-type connection M12x1 . . . . .	17+18
9.3.2	Grease level monitoring with cubic plug acc. to DIN 43650 . . . . .	18
9.3.3	Micro switch at the pressure relief valve . . . . .	19
10.	Pump elements:	
10.1.	Pump element PE-60, PE-120 and PE-170. . . . .	20
10.2.	Pump element PE-120 V . . . . .	20+21
10.3.	Installation and removal of the pump elements . . . . .	21
10.4	Ventilation of the pump . . . . .	21
10.5	Special accessory malfunction indicator at pressure relief valve. . . . .	22



11.	Function of the control units:	
11.1.	Control unit BEKA-troniX1 and EP-tronic . . . . .	22
11.1.1.	Operating mode time control and rotary control . . . . .	22+23
11.1.2.	Operating mode cycle control . . . . .	23
11.1.3.	Special equipment - internal data memory . . . . .	24
11.1.4.	Adjustment of the operating mode and the adjustment ranges . . . . .	24+25
11.1.5.	Optional equipment . . . . .	26
	Grease level monitoring for BEKA-troniX1 and EP-tronic . . . . .	26
	Pressure relief valve monitoring for BEKA-troniX1 and EP-tronic . . . . .	26
	Starter release or collective fault signal at EP-tronic . . . . .	27
	Adaption to the application conditions at EP-tronic . . . . .	27
11.2.	Function of the control unit EP-tronic T1	
11.2.1	Function sequence . . . . .	28
11.2.2.	Extras . . . . .	29
11.3.	Function sequence of the control unit EP-T2 . . . . .	30
12.	Adjustment of the control units:	
12.1.	Adjustment of the parameters . . . . .	31
13.	Filling of the pump:	
13.1.	Standard filling via lubrication nipple with manual or pneum. grease gun . . . . .	32
13.2.	Filling via filler coupling . . . . .	32
13.3.	Filling via filling press . . . . .	32
14.	Signals . . . . .	33
15.	Ventilation of the pump . . . . .	34
16.	Service and maintenance . . . . .	34
17.	Disposal . . . . .	34
18.	Spare parts drawing . . . . .	35-37
19.	Spare parts list . . . . .	38-41
20.	Order key of level monitoring . . . . .	41
21.	Order key of integrated control unit:	
21.1	Control unit EP-tronic . . . . .	42
21.2	Control unit EP-tronic T1 . . . . .	43
21.3	Control unit BEKA-troniX1 . . . . .	43
21.4	Control unit EP-T2 . . . . .	44
22.	Error - Cause - Remedy . . . . .	45+46
	Details on the manufacturer . . . . .	48



## Declaration of incorporation for incomplete machinery (acc. to EC-directive 2006/42/EG)



The manufacturer: BAIER + KÖPPEL GMBH+CO. KG  
Beethovenstrasse 14  
91257 Pegnitz / Germany  
Tel.: +49 9241 729-0

declares hereby, that the following partly completed machinery:

Product description: FETTSCHMIERPUMPE  
Type designation: EP-1, FKGGM\_EP  
Article number: 2018...; 2037...; 2152...; 2157...; 2175...; 2183...; 2184...  
Serial number: from 930000 to 999999

**is complying with all essential requirements of the above mentioned machinery directives (2006/42/EG):  
Annex I, article 1.1.2, 1.1.3, 1.1.5, 1.3.2, 1.3.4, and 1.5.1.**

The following coordinated standards have been used:

DIN EN 809  
DIN EN ISO 12000

The following other specifications and standards have been used:

VDE 0530

The protection targets of the directive for **electric equipment 2006/95/EG** have been observed according to the annex I, no. 1.5.1 of the machine directive.

The incomplete machine may only be put into service as soon as there has been stated that the machine, into which the incomplete machine shall be installed, responds to the determinations of the machine directive (2006/42/EG).

The special documentation that responds to the machine, has been prepared according to annex VII part B.

The manufacturer (documentation department, phone +49 9241 729-779, email: [tb3@beka-lube.de](mailto:tb3@beka-lube.de)) obliges itself to pass on electronically the special documentation for partly completed machinery to individual national authorities upon request.

Pegnitz, 27.03.2013

ppa. A. Zapf (sales manager)

## 1. Legend:

Safety instructions which, if not complied with, may endanger persons, are marked specifically with the general hazard symbol:



This heading is used if inaccurate compliance or non-compliance with the Operating Instructions or specified work procedures etc. may result in damage:

**Attention!**



Points out special information:

**Note!**

## 2. Warranty and extent of warranty:

**Note!**

Inappropriate intervention will rule out your warranty claim!

Warranty regarding operational safety, reliability and performance of the lubricating pump is only accepted by the manufacturer under the following conditions:

- Assembly, connection, setting, maintenance and repair are carried out by authorized and specialized staff.
- The limits stipulated in the technical data must never be exceeded.
- Only original components or components approved by the manufacturer may be used for repair and maintenance work.

All guarantees and warranties expire for damages to central lubrication systems that are caused by operation with improper lubricants (e.g. piston wear, piston jamming, pluggings, embrittled sealings).

**Attention!**

BEKA does not assume liability on damages caused by lubricants, even if these lubricants have been tested and released by laboratory tests, as damages caused by lubricants (e.g. by expired or improper stored lubricants, batch variations etc.) can not be retraced to their root cause in retrospect.

## 3. Safety information:

### General information

Any safety-related faults must be eliminated without delay.

Below, please find fundamental instructions to be complied with, regarding assembly, operation and maintenance. The mechanical and the competent specialists / staff of the operating company must read the Operating Instructions on all accounts prior to starting assembly and commissioning. Moreover, the Operating Instructions must permanently be available on site.

Not only the safety instructions included under this item, but also the specific safety instructions appearing in other parts of this manual must be complied with.

### General risk reference

All system components have been designed in view of operational safety and accident prevention according to the applicable provisions for the design of technical equipment.

Nevertheless, utilization thereof may result in risks for the user or third parties and/or technical equipment. Thus, the system may only be used in proper technical working within its intended fields of application and in compliance with the safety provisions and the Operating Instructions.

Personal:

The staff in charge of operation, maintenance, inspection and assembly must be qualified accordingly for this work. The operating company must stipulate competences, responsibilities and the supervision of staff precisely. If the staff does not dispose of the appropriate knowledge, they must be trained and instructed. The operating company must ensure that the staff have understood the contents of the Operating Instructions.

EN

Danger due to non-observance of the safety information:



Non-compliance with the safety information may put persons at risk and endanger the environment and/or the machine. Non-compliance with the safety instructions may rule out any claims for damages.

. Non-compliance may lead, e. g. to the following dangers:

- Failure of important system functions.
- Failure of the specified maintenance and servicing methods.
- Endangering people due to electrical, mechanical and chemical effects.
- Endangering the environment due to leakages of dangerous materials.

Use in conformity with the intended purpose:

The pumps of the series EP or FKGGM-EP serve only for the supply of central lubrication pumps at vehicles, systems and machines.

Any use beyond this scope is regarded as being not in conformity with the intended purpose.

6

Disclaimer of liability:

BEKA is not liable for damage caused by:

- lack of lubricant
- contaminated or unsuitable lubricants
- any use which is not in conformity with the intended purpose
- inappropriate installation and filling
- wrong electrical connection
- wrong setting of the control unit
- improper reactions to malfunctions
- non-observance of the operating instructions

Assembly and maintenance works:

Observe for all assembly works at vehicles, systems and machines the valid local accident prevention regulations and safety instructions as well as the specifications for operation and maintenance.



All maintenance, inspection and assembly work may only be carried out by trained specialists. All work must only be carried out when the plant is at a standstill and while wearing appropriate protective clothing.

All the safety and protective equipment must be replaced immediately after completing work. Media that endangers the environment must be disposed in accordance with pertinent official specifications. Secure the system during maintenance and repair works, against intentional or unintentional reoperation.

Dispose of process materials in accordance with the safety data sheets of the lubricant manufacturer.

Safety information for operators/operating staff:



- If hot or cold machine parts lead to hazards, the customer must secure them from being touched. The guards on moving or rotating parts must not be removed.
- Drain leakages of dangerous materials in a way, that people or the environment are not endangered.
- Comply with legal regulations.
- Exclude any hazards by electric energy.

EN

Unauthorized modification and spare part production :



Modifications and alterations of the system require the manufacturer's prior approval. Original spare parts and accessories authorized by the manufacturer serve for higher safety. The use of other parts may rule out liability for the consequences of such use. For components, which are retrofitted by the operator, BEKA does not assume liability nor claims for compensation.

Danger caused by the electrics:

The units may be connected to the power supply exclusively by appropriately trained qualified personal in conformity with the local connection conditions and regulation (e. g. DIN, VDE)! Improperly connected equipment may lead to serious personal injury and damage to property!

7

Danger caused by system pressure:

The units might be under pressure.  
Make them pressureless before you start with repairs, changes or extensions.

Use of hydraulic hose lines:



Installing hydraulic hose lines at the pump, the operator has to observe respectively ensure the following items:

- Checks for proper assembly and function have to be carried out according to the regional valid guidelines.
- Checks for a safe provisioning and use have to be carried out according to the regional valid guidelines.
- The check deadline must not be exceeded.
- Exchange defect hydraulic hose lines immediately and professional.
- Hydraulic hose lines subject to a wear process and have to be exchanged regularly and according to the manufacturer's details.

Lubricant:

The system has been designed for commercially available multi-purpose greases of NLGI class 2 for operation in summer and winter.

- Use greases with high-pressure additives (EP greases).
- Only use greases of the same saponification type.
- Lubricants containing solid contents must not be used (lubricants like graphite or MoS<sub>2</sub> on request).
- Observe the vehicle manufacturer's specifications, when you select the lubricant.



Hazards to environment cause by lubricants:

The lubricants which are recommended by the manufacturer of your vehicle, system or machine correspond in their composition to the common safety regulations. Mineral oils and greases are generally hazardous to ground water and their storage, processing and transport requires special precautions.

Inadmissible methods of operation

Operational security of the plant is only guaranteed if it is operated in accordance with the operating instructions. The limit values stated in the technical data must not be exceeded under any circumstances.

Transport and storage of the pump:

The pumps of the series EP are packed commercially, according to the regulations of the recipient country and to the wish of the customer.

There are no limitations with respect to land, air or sea transport.

Store in a dry place at a temperature of -40° C to +70° C.

8

**Attention!**

**Handle with care!**

## 4. Technical data:

**Motor EP-1, FKGGM-EP:**

Operating voltage:	12 V DC / 24 V DC
Speed:	15 rpm.
Current consumption:	
Idle running at +20° C:	0.8 A / 0.4 A
Full load at +20° C:	2.2 A / 1.1 A
Fuse:	5 A / 3 A

**Motor FKGGM-EP with PSU:**

Operating voltage:	24 V DC
Connection voltage:	230 V AC / 50 Hz
	115 V AC / 60 Hz
	(via installed PSU)
Current consumption:	max. 0.2 A (230 V AC)
Speed:	15 U / min.
Duty cycle:	10 % ED (10 min)
Operating temperature:	-20° C to +70° C



**Pump:**

max. operating pressure:	350 bar
Adjustment of overpressure valve:	280 bar
Operating temperature:	-35° C to +70° C
Reservoir size :	
Transparent reservoir:	1,9 kg, 2,5 kg, 4 kg, 8 kg or 16 kg
Steel reservoir:	2 kg or 4 kg
Direction of agitator blade:	counter-clockwise
Installation position:	reservoir in vertical position
Output rate:	depending on pump element
Protection type:	IP5K9K at DIN 40050
Weight:	EP-1, FKGGM-EP DC: approx. 5.1 kg FKGGM-EP with PSU: approx. 5.8 kg



**Control units BEKA-troniX1, EP-tronic, EP-tronic T1:**

Operating voltage:	10 to 60 V DC
Max. current load:	I = 6 A
Fuse (not including in device):	F 6.3 A (5x20) medium
Signal lamp outlet:	I <sub>max.</sub> = 0.4 A
Operating temperature:	-35° C to +70° C
Sound pressure level:	< 70dB(A)

**Control unit EP-T2:**

Operating voltage:	10 to 33 V DC
Max. current load:	I = 6 A
Fuse (not included in device):	F 6.3 A (5x20) medium
Signal lamp outlet:	I = 0.4 A
Operating temperature:	-35° C to +70° C

## 5. Assembly manual:



The following conditions have to be satisfied during the assembly of this grease lubrication pump, thus it can be assembled, with other parts, to a complete machine without affect the safety and health of human.

EN

Set up the grease lubrication pump horizontally on both sides at the place where it has to be installed! Pay also attention to the mentioned data regarding the fastening bore in the dimensioned drawing.

Special measures for the noise prevention and for the vibration reduction of the grease lubrication pump during the installation don't have to be taken.

### Pipeline and hydraulic hose line assembly

- Layout must be expert. Assemble free from distortion.
- Comply with the pressure seal tightness of the threaded joints.
- Please observe the permitted pressure range of the pipeline and the hydrauc hose line.

### Electrical connection



- Current supply may only be made by professional electricians
- The electrical components of the system must be wired expert.
- Compare the voltage details with the existing mains voltage

10

## 6. Overview and installation dimensions:

### 6.1. Central lubrication pump EP-1 and FKGGM-EP with steel reservoir:

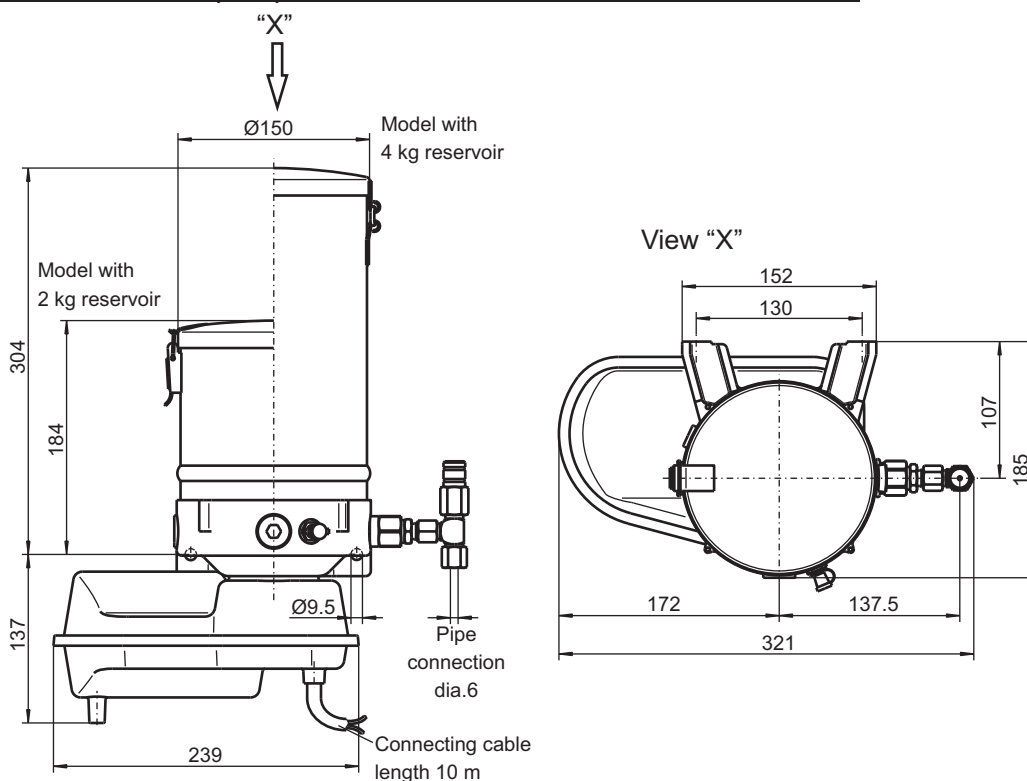

6.2. Central lubrication pump EP-1 and FKGGM-EP with transparent reservoir:

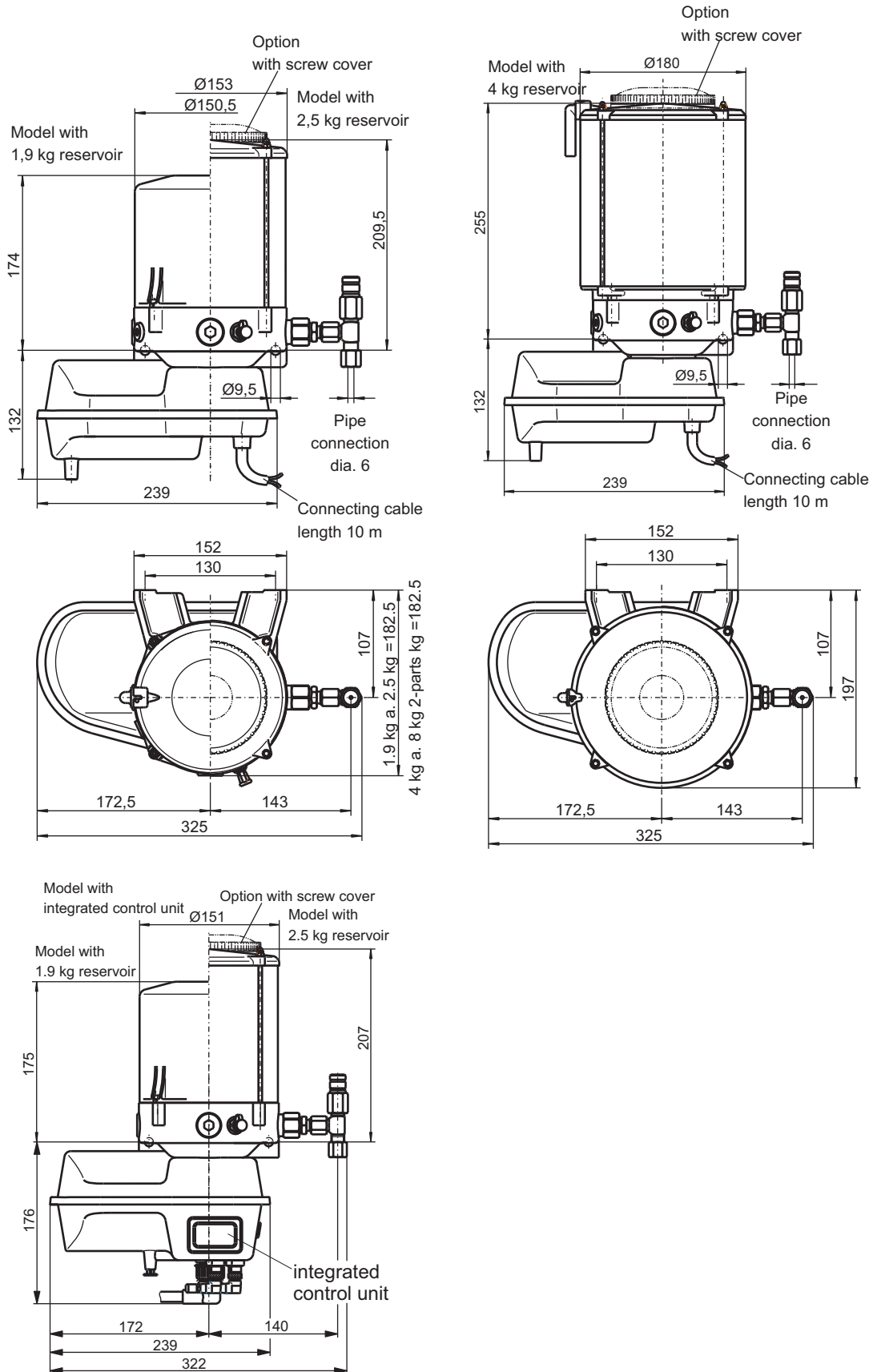



12

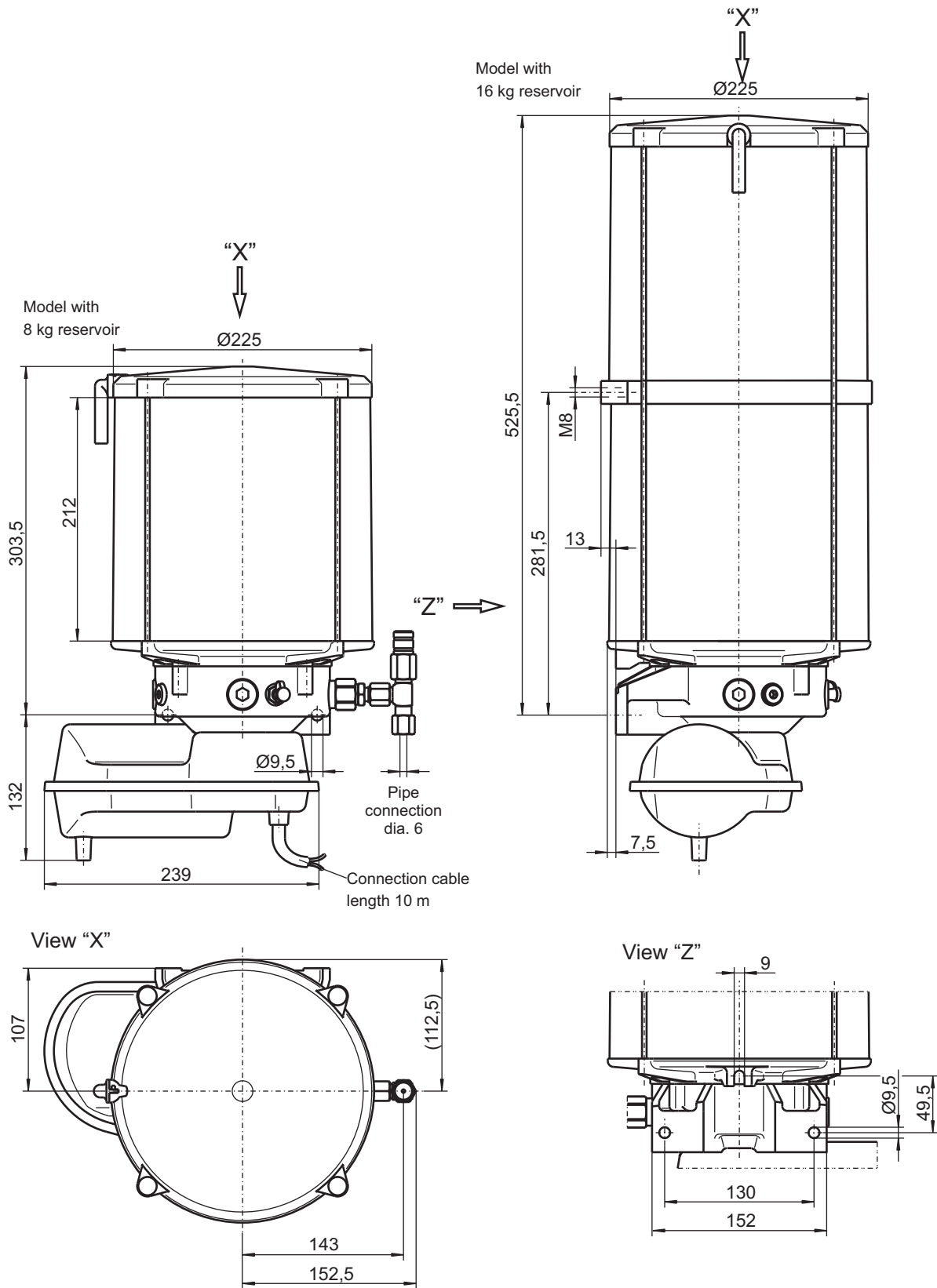

## 7. Terminal diagrams:

### 7.1. Central lubrication pump EP-1 and FKGGM-EP without control unit:

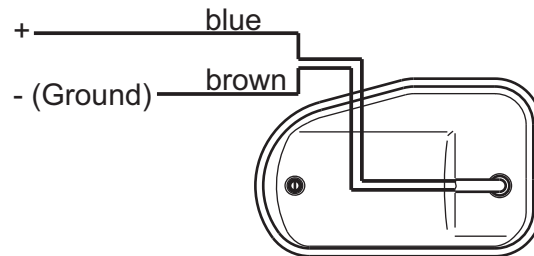

### 7.2. Central lubrication pump EP-1 without control unit: Special model with bayonet connector:

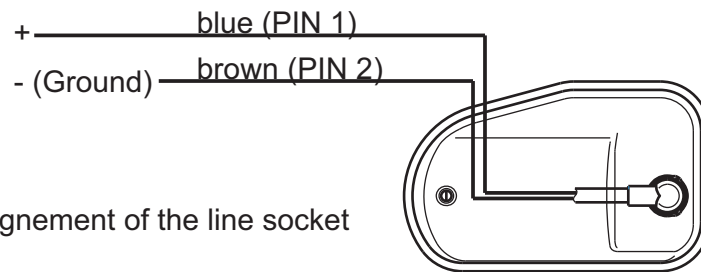

(PIN ...) = Assignment of the line socket

7.3. Central lubrication pump EP-1 and FKGGM-EP with integrated control unit BEKA-troniX1:

EN

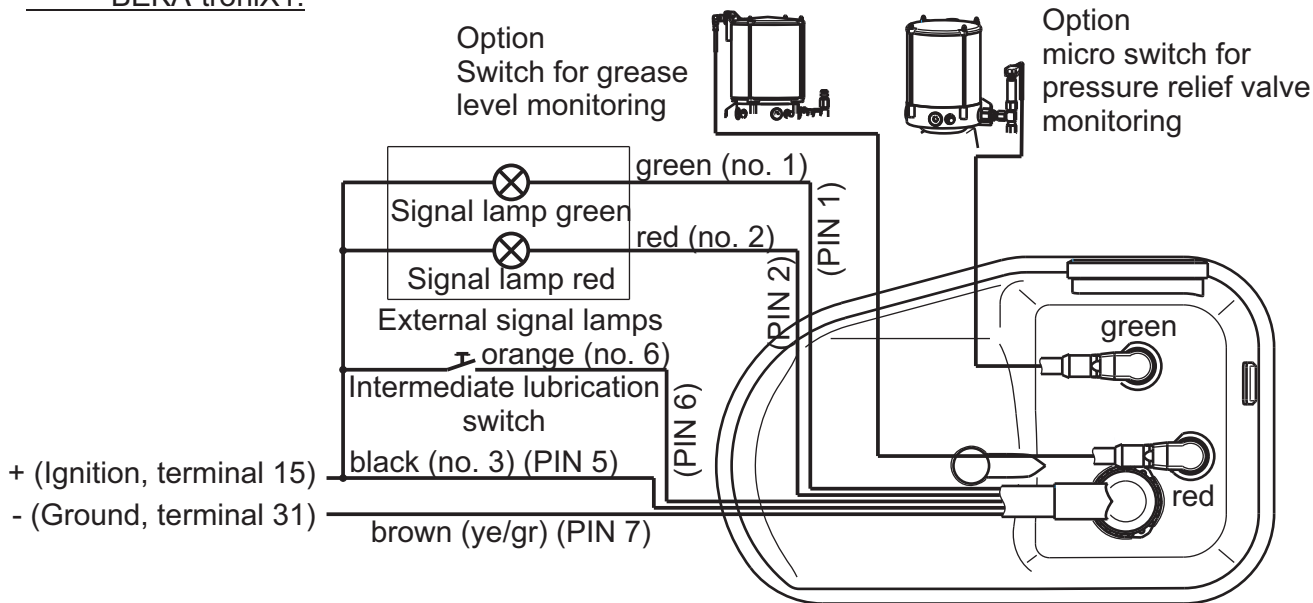

(no. ...) = Cable-no. at uni-colored cables  
(PIN ...) = Assignment of the line socket

# 14

7.4. Central lubrication pump EP-1 with integrated control unit EP-tronic T1:

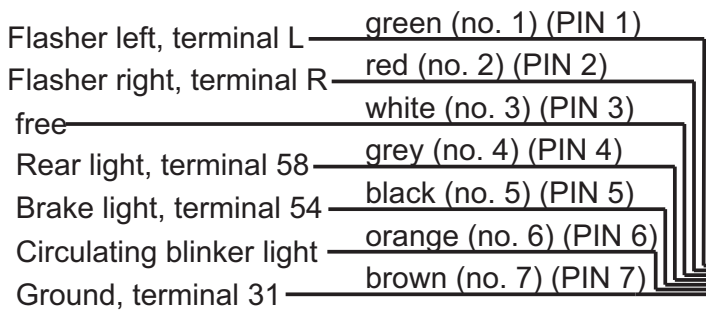

(no. ...) = Cable-no. at uni-colored cables  
(PIN ...) = Assignment of the line socket

7.5. Central lubrication pump EP-1 with integrated control unit EP-T2:

- (Ground, terminal 31) — brown (PIN 7)
- + (Brake light, terminal 54) — blue (PIN 5)

(PIN ...) = Assignment of the line socket

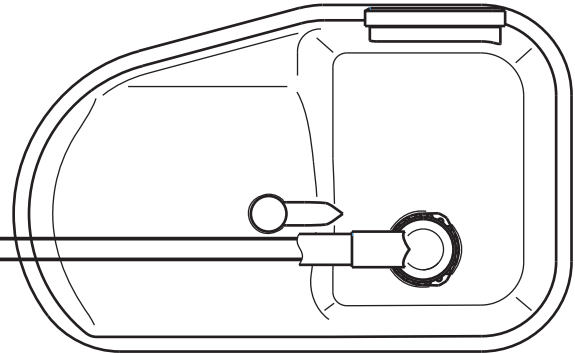

EN

7.6. Central lubrication pump EP-1 and FKGGM-EP with integrated control unit EP-tronic:

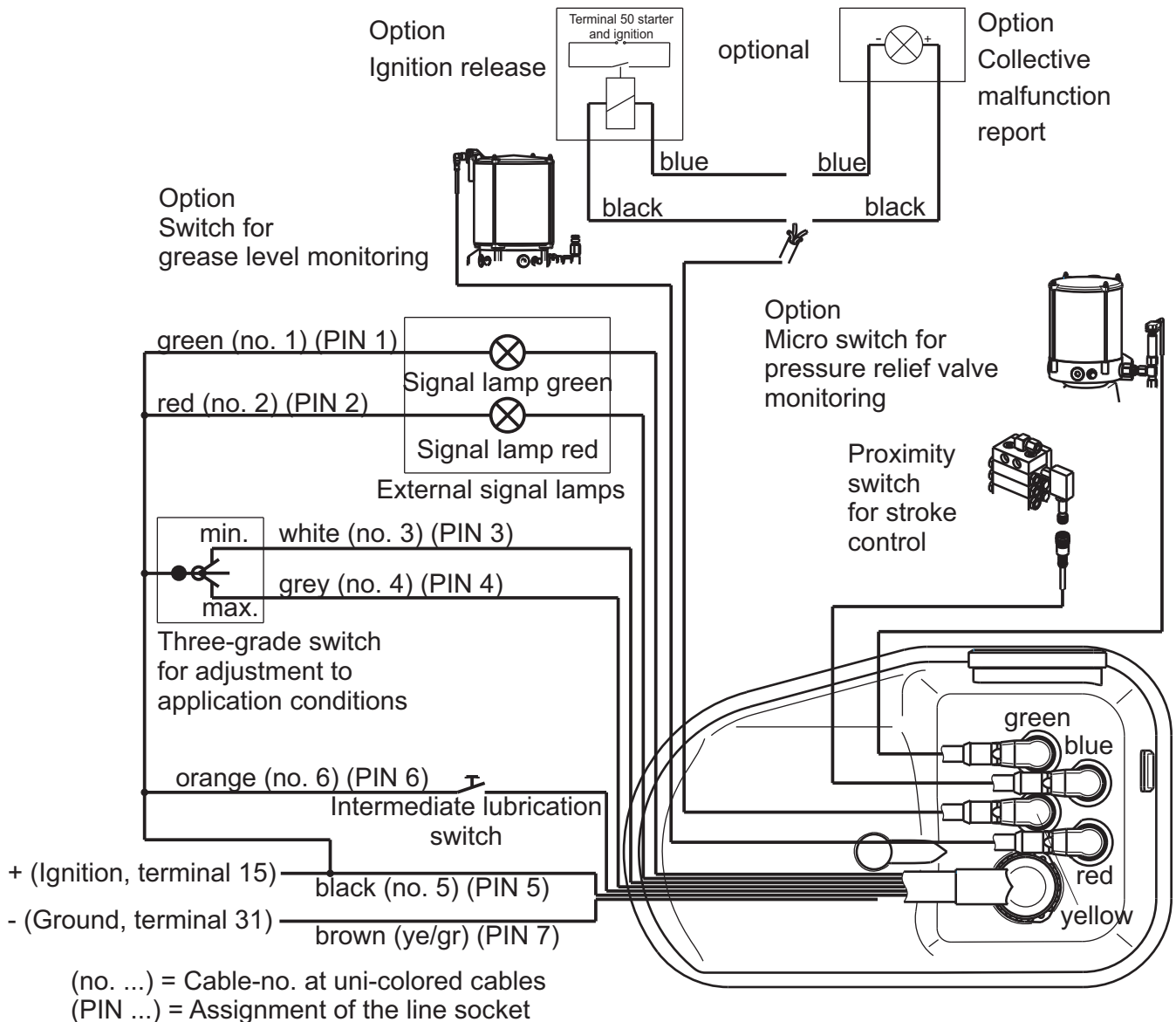

15

BAL\_21152\_EP1\_Central grease lubrication pump\_0816\_EN EDV-Nr. 1090200430

7.7. Central lubrication pump FKGGM-EP with power supply unit (PSU):

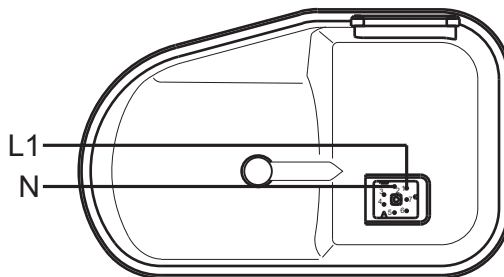

Pay attention to the voltage of the power supply unit when connecting. The voltage is indicated on a sticker in the inspection window of the lower motor shell (115 V or 230 V).

8. Function and design of the system:

The central lubrication system into which an electrical pump EP-1 or FKGGM-EP is installed, is a progressive system. Progressive means that the lubrication points are lubricated in sequence. The sequential lubrication means a pressure relief valve can easily monitor the progressive central lubrication system.

16

The central lubrication pump EP-1 delivers the lubricant to the main distributor. The main distributor's task is to distribute the lubricant to the secondary distributors in the right proportions. The secondary distributors then deliver the lubricant to the individual lubrication points. Should a lubrication point do not receive lubricant from the distributor, the system would block and a pressure of up to 280 bar is built up in the line system. Does the system block but is nevertheless operating properly, the lubricant comes out of the pressure relief valve of the pump. This serves for the system protection and monitoring.

Installation example:

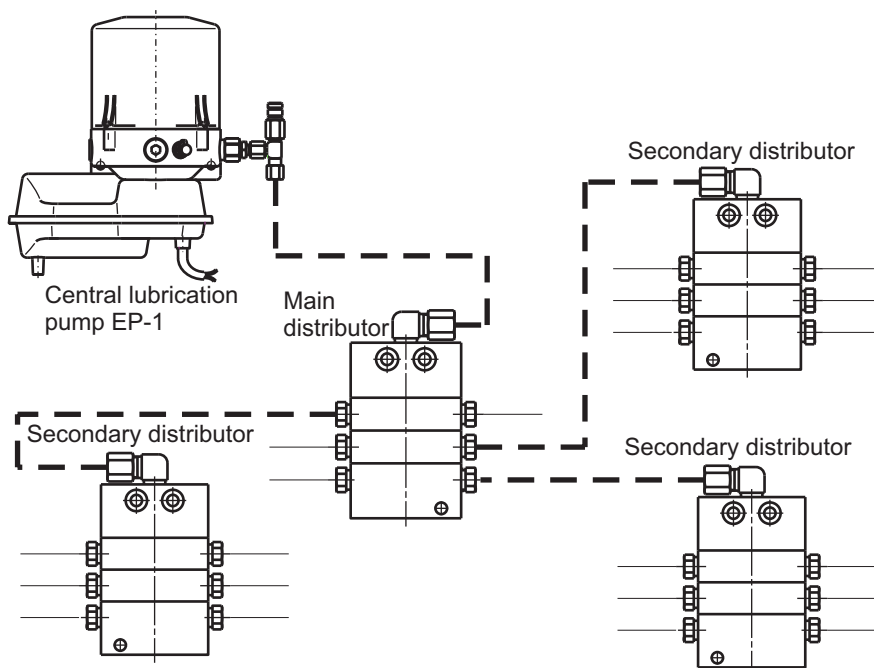



## 9. Function of the central lubrication pump:

The central lubrication pump EP-1 or FKGGM-EP is designed for delivering lubricant up to NLGI class 2. The agitator blade pushes the lubricant through a grease sieve to the intake section of the pump element. The pump element is positively driven by an eccentric so that function is also ensured at low temperatures. The output rate depends on the installed pump element (see page 20).



### 9.1. Without control unit:

At pumps without control unit can the lubrication cycle be controlled by an on-board controller, a machine control or PLC.

### 9.2. With PE-120 V:

For trailers and semi-trailers, it is not possible to ensure a permanent current supply of the pump or the control unit. Therefore is a central lubrication pump without control and with adjustable pump elements installed into such vehicles. The pump gets its operating voltage via the brake light and thus the pump always lubricates with each braking. The lubricant can be reduced with the adjustable pump element (see adjustment of the pump element on page 21).

### 9.3. Special equipment of the central lubrication pump without control unit:

#### 9.3.1. Grease level monitoring with plug-type connection M12x1 (Standard):

At the electrical pump EP-1 or FKGGM-EP can the grease level be checked visually through the transparent reservoir.

However, there is also the possibility to monitor the grease level in the reservoir electronically. A capacitive proximity switch is installed into the reservoir for this purpose. This switch emits a signal as long as there is sufficient grease in the reservoir. If the grease falls below a certain level, the proximity switch stops this signal.

The signal can be evaluated by an external control or PLC. Evaluation should only be done after a period of approx. 10 sec. If there is no signal for longer than 10 seconds, the reservoir is empty and the pump should be switched off.

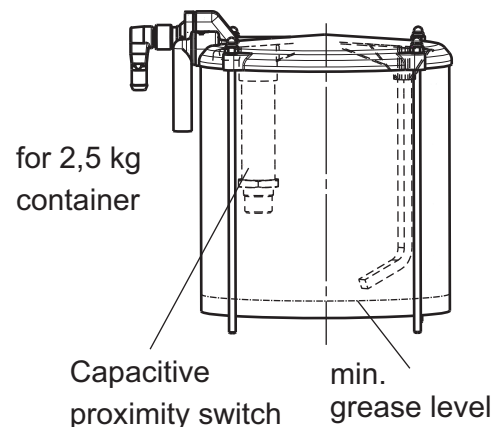

**Attention!**

Not keeping to the period of 10 sec. can cause level errors although the reservoir is filled with grease.

Terminal diagram for connecting the capacitive proximity switch to an external control unit:

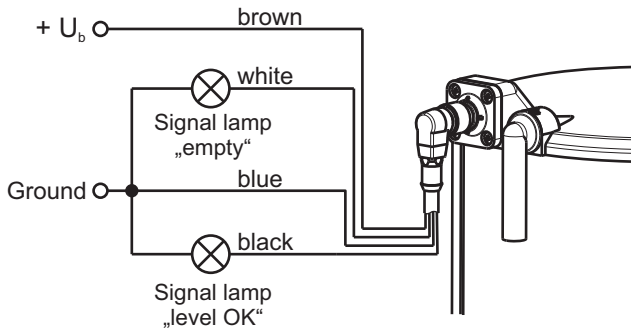

EN

Technical data:

**Standard version** **-20°C - +70°C**  
**Supply voltage:** **10 to 60 V DC**  
 Connecting method: PNP-NO (normally open contact)  
 Switching current, max.: 250 mA  
 Protection class of switch: IP 67  
 Connection: 4-pole M12x1 pluggable

**Low temperature version** **-40°C - +70°C**  
**Supply voltage:** **12-30 V DC**  
 Connecting method: PNP-NO (normally open contact)  
 Switching current: min. 20 mA  
 Protection class of switch: IP 67  
 Connection: 4-pole M12x1 pluggable

**Note!**

The brown wire (+U<sub>b</sub>) and the blue wire (ground) are used for voltage supply of the sensor.  
 If the black wire is used as output of the sensor, it works as a closing contact, and +U<sub>b</sub> is issued if the reservoir is empty (OK-signal, line break monitoring).  
 If the white wire is used as sensor output it works as opening contact and +U<sub>b</sub> is issued if the reservoir is empty (empty message).

18

9.3.2. Grease level monitoring with cubic plug acc. to DIN 43650:

The grease level monitoring can also be connected via a cubic plug.

The functions correspond to those described on the previous page, of the grease level monitoring with plug connection M12x1.

Die Schließer- oder Öffnerfunktion muss bei Bestellung ausgewählt werden.

Wiring diagram with supply voltage of 10-60 V DC:

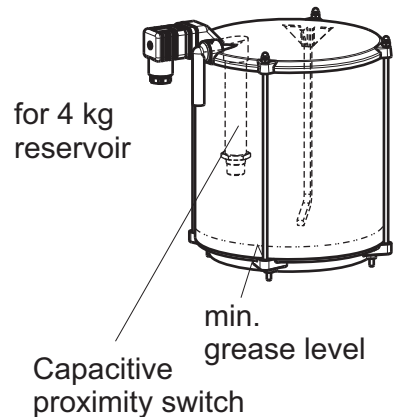
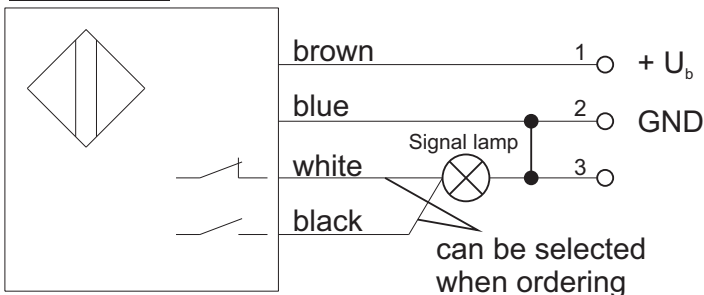

Technical data:

**Supply voltage:** **10 to 60 V DC**  
 Connection method: PNP-NO (normally open contact)  
 Switching current: at 70°C: 250 mA  
 Current consumption: without load: <20 mA  
 Protection class: switch: IP 67  
 switch: IP 54  
 Ambient temperature range: **-20°C - +70°C**

**Wiring diagram with supply voltage of 90-250 V AC:**

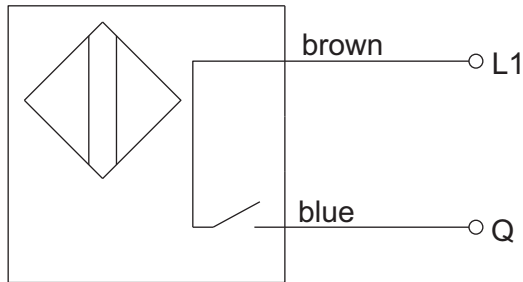

Pole assignment:  
 Compact plug connection, 3 poles+ PE  
 No. 1 = L1  
 No. 2 = free  
 No. 3 = Q  
 ⊥ = yellow/green (only for max.)



Technical data:

**Supply voltage:** 90 to 250 V AC  
 Connecting method: NO contact (Tyristor outlet)  
 Switching current: at 70°C: min. 5 mA  
 max. 250 mA  
 Protection class: switch: IP 67  
 plug: IP 54  
 Ambient temperature range: -25°C to +70°C

9.3.3. Micro switch at pressure relief valve:

The micro switch at the pressure relief valve is used for monitoring the maximum operating pressure in the central lubrication system.

If a malfunction occurs in the system, the micro switch is actuated.

The micro switch signal can be processed by any already existing signal encoder, e. g. an on-board controller, or by an external or integrated control unit.

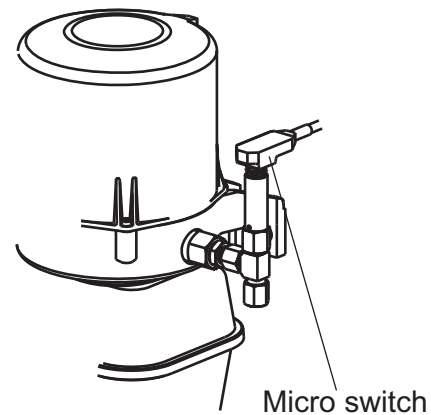

The lubricant comes out under high pressure (250 bar)!  
 Wear safety goggles and also do not stay otherwise within the area of the pressure relief valve in the case of a malfunction of the central lubrication unit!  
 Never work when the voltage (ignition) of central lubrication system or pump is connected! Relieve the central lubrication system before you start the works!

Terminal diagram for connecting the micro switch to an external control unit:

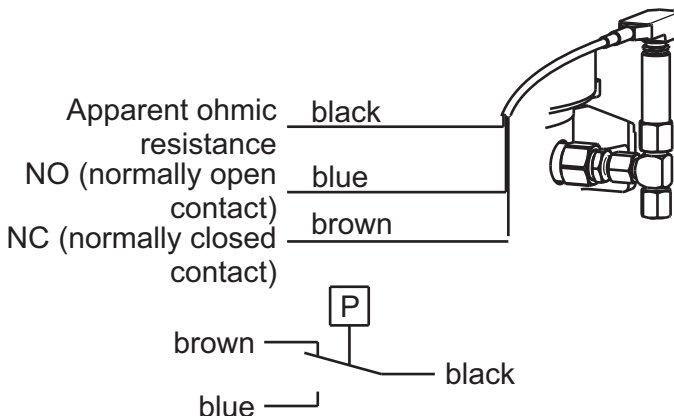

Technical data:

Supply voltage: 10 to 60 V DC  
 max. current load: I = 1,7 A  
 Contact type: 1 changeover switch  
 Temperature range: -25° C to +85° C  
 Protection class: IP 67  
 Connection: Cable, length 0.5 m, welded

## 10. Pump elements:

There are different pump elements available for the installation into a central lubrication pump EP-1 or FKGGM-EP. You cannot adjust the output rate at the pump elements PE-60, PE-120 and PE-170 but at the pump element PE-120 V this is possible.



PE-60, PE-120, PE-170:

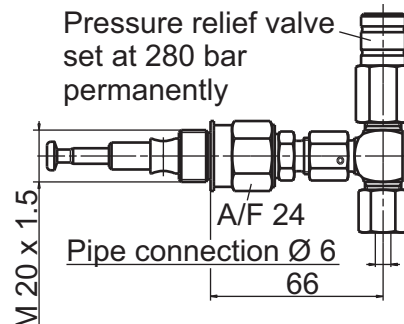

### 10.1. PE-60, PE-120 and PE-170:

Technical data:

	Output rate (cm <sup>3</sup> / stroke or rev.)	Order-no. (incl. pressure relief valve)	Order-no. Pressure relief valve
PE-60	0.06	2152 99067 0000	2152 0062
PE-120	0.12	2152 99061 0000	
PE-170	0.17	2152 99069 0000	

Delivery medium:

Grease from NLGI-KI. 00/000 to NLGI-KI. 2

Piston return:

positively controlled

20

### 10.2. PE-120 V:

Technical data:

Output rate: . . . . . 0,04 to 0,12 cm<sup>3</sup>/stroke

Output rate regulation: . . . . . 6 notches with 1/2 a revolution each

Reduction: . . . . . 0,013 cm<sup>3</sup> per notch

Delivery medium: . . . . . grease from NLGI-KI. 00/000 to NLGI-cl. 2

Piston return: . . . . . positively controlled

Order-no. (incl. pressure relief valve): . . . . . 2152.99063.0000

Order-no. pressure relief valve for PE-120 V: . . . . . 2152 0063

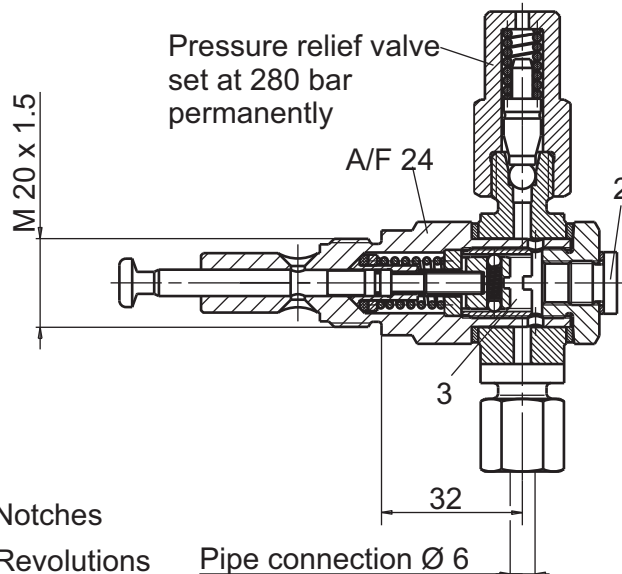
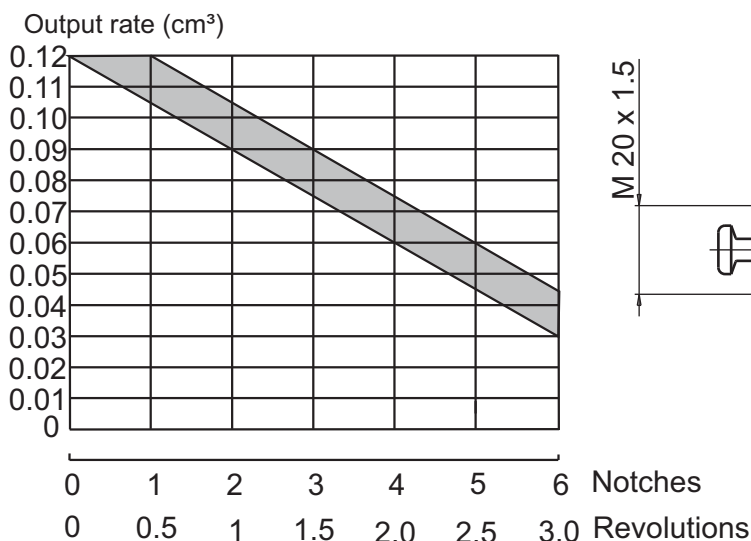

Adjusting the delivery rate:

- All pump elements are set to full stroke by the manufacturer.
- Remove screw plug (2) with Allen key (A/F 5).
- Set screw (3) can be turned with a screwdriver.
- Turning clockwise reduces the output rate.
- Turning counter-clockwise increases the output rate.
- Maximum stroke of set screw is 2.4 mm = 6 notches.
- 1 turn of set screw is 0.8 mm = 2 notches.
- Tighten screw plug (2) incl. sealing ring.



10.3. Installation and removal of the pump elements:

- Only install / remove when pump is off.
- Install pump element with partially extended piston (4) and insert it at an angle into the housing drilling (see diagram A).
- When the piston head rests on pressure ring - move element into vertical position (see diagram B).
- Piston head must run in guide ring groove.
- Tighten the pump elements.
- For removal, reverse above sequence.
- When removing the pump element, ensure that the piston (4) is not left behind in the pump housing.

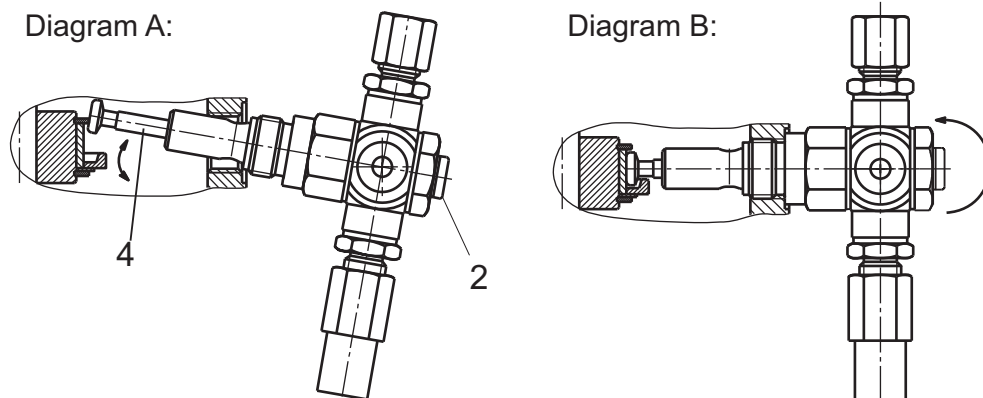

**Attention!**

The pump element or the pump are destroyed at first operation, if the pump element has not been positioned correctly.

10.4 Ventilation of the pump

- Remove screw plug (2) with Allen key (A/F 5).
- Screw the adjusting screw (3) by means of a screw driver until stop
- Start the pump
- Screw back the adjusting screw (3) by 1 notch per revolution of the agitator blade
- Operate the pump until oil comes out of the screw plug thread
- Assemble the screw plug (2) incl. sealing ring and tighten it

10.5. Special accessory malfunction indicator at pressure relief valve:

The pump elements for the electric pump EP-1 can be equipped with a visual malfunction indicator. If a malfunction occurs in the central lubrication system and the operating pressure increases above 280 bar, the red control pin becomes visible. The grease escaping through the pressure relief valve is returned into the reservoir. Once the malfunction is remedied, the red control pin must be pushed back.

EN

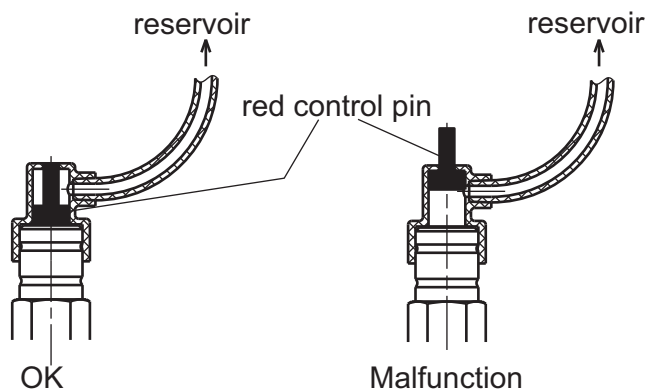
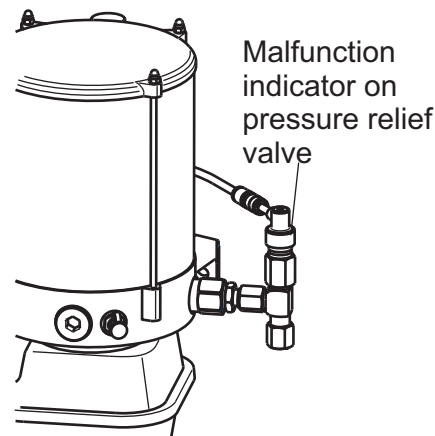

**22** 11. Function of the control units:

11.1. Control unit BEKA-troniX1 and EP-tronic:

11.1.1. Operating mode time control and rotary control

The control unit BEKA-troniX1 and EP-tronic operate lubrication cycle dependant. The lubrication cycle is divided into lubrication time and cycle time. Diagram of a lubrication cycle:

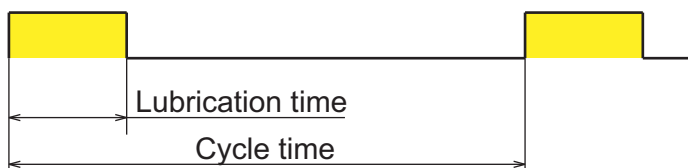

Independent on the adjusted program, the green and the red LED in the inspection window of the control unit glow for approx. 1,5 sec. after switching on the ignition, thus signalling the function of the control unit (turn-on check).

With each initial activation of the pump starts a lubrication process. The green LED in the inspection window of the control glows during the whole lubrication process.

The control unit has a data memory. It serves, among other things, for saving the run-down times. When the ignition is interrupted, the remaining lubrication- or cycle time is saved. Once the ignition is switched on again, are the times read in the memory and the procedure is continued where it has been interrupted before.

With switched on ignition an intermediate lubrication can any time be initiated by actuating the button at the side of the pump. The pump immediately starts with lubrication then. The remaining cycle time or lubrication time is reset and starts from the beginning again. You can reset a malfunction by pressing the button for intermediate lubrication. The pump then tries to start a new lubrication process again.

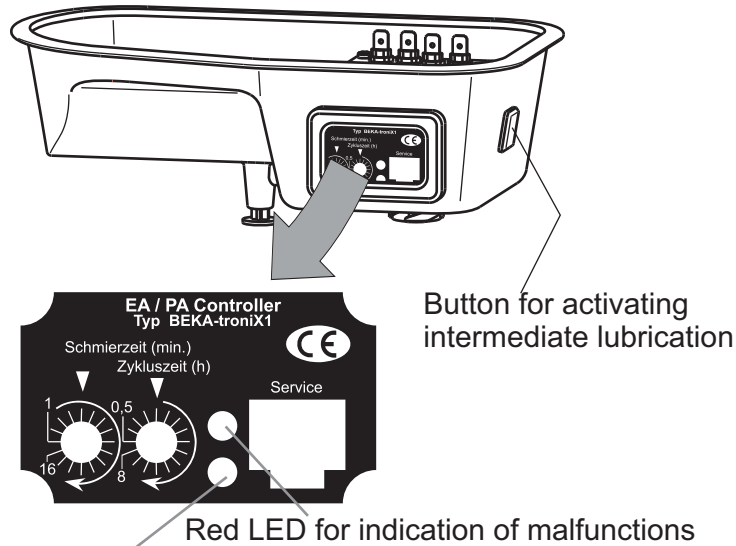

Control by time      Green LED for indication of the function  
 With the mode time control can lubrication time and cycle time be adjusted.

Control by revolutions:

With the control by revolution is the lubrication duration determined by the number of revolutions of the pump motor. The pump motor is connected to the control unit via sliding contacts. The control unit receives a signal with each motor revolution.

11.1.2. Operating mode cycle control:

At the sequential control is the number of piston strokes of the progressive distributor counted, in order to determine duration of the lubrication period.

To this purpose is a proximity switch mounted at the progressive distributor, which is connected to the control unit (see terminal diagram on page 15). A signal is sent to the control unit with each piston stroke.

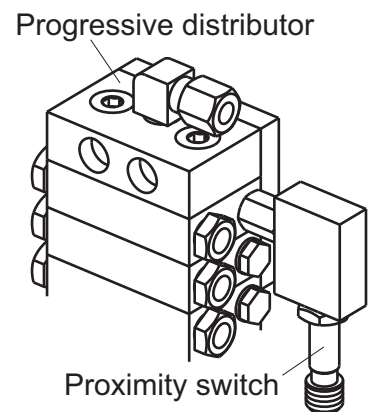

Technical data of the proximity switch:

Operating voltage:	10 to 60 V DC	Function display:	LED yellow
Connection method:	PNP-NO (normally open contact)	Housing material:	stainless steel
Power rating:	200 mA	Protection class of switch:	IP 67
Connection:	4 poles, M12x1 pluggable	Ambient temperature range:	-40° C to +85° C

### 11.1.3. Special equipment

#### Internal memory:

The below listed values are saved at the control unit BEKA-troniX1. They can be read out or changed with the diagnosis software BEKA-DiSys:

- Controlling type
- Version of control unit
- Serial number
- Manufacturing date
- Operating mode
- Set parameters (adjusting ranges)

EN

The control unit EP-tronic additionally saves the following values:

- RTC (Real-Time-Clock) date and time, also adjustable for other time zones
- Operating hours
- Running time of the pump
- Number of intermediate lubrication
- Number of filling errors
- Number of excess pressure errors
- Number of stroke monitoring errors
- Number of revolution monitoring errors
- Date and time of last diagnosis
- Number of total diagnosis
- List of the last 100 errors with error type, as well as indication of time and date
- List of the last 100 changes of the adjustment with time and date

24

For a modification of the above mentioned values is the diagnosis software BEKA-DiSys as well as a data cable necessary (see description BEKA-DiSys).

### 11.1.4. Adjustment of the operating mode and the adjustment ranges:

The modes and the adjusting ranges can be changed by means of the diagnostic software BEKA-DiSys.

All adjusting ranges for the lubrication time can be combined with all cycle time ranges.

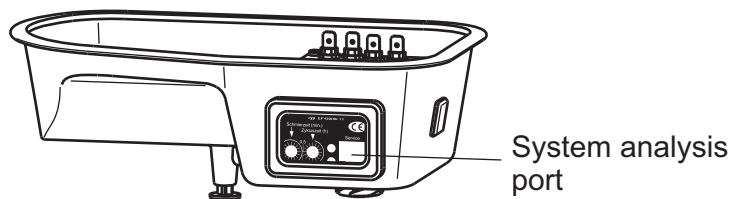

#### Adjusting ranges BEKA-troniX1:

##### Lubrication times:

- 1 to 16 min. (16 notches every 1 min.)
- 2 to 32 min. (16 notches every 2 min.)
- 2 to 32 sec. (16 notches every 2 sec.)

##### Cycle times:

- 0.5 to 8 h (16 notches every 0.5 h)
- 2 to 32 min. (16 notches every 2 min.)
- 2 to 32 h (16 notches every 2 h)

##### Revolutions of the pump:

- 1 to 16 revolutions (16 notches every 1 revolution)
- 10 to 160 revolutions (16 notches every 10 revolutions)
- 170 to 320 revolutions (16 notches every 10 revolutions)



Adjusting ranges EP-tronic:

Lubrication times:

1 to 16 min. (16 notches à 1 min.)  
 2 to 32 min. (16 notches à 2 min.)  
 2 to 32 sec. (16 notches à 2 sec.)

Cycle times:

0.5 to 8 h (16 notches à 0.5 h)  
 2 to 32 min. (16 notches à 2 min.)  
 2 to 32 h (16 notches à 2 h)

Strokes:

1 to 16 cycles (16 notches à 1 cycle)  
 17 to 32 cycles (16 notches à 1 cycle)  
 33 to 48 cycles (16 notches à 1 cycle)

Revolutions:

1 to 16 revolutions (16 notches à 1 revolution)  
 10 to 160 revolutions (16 notches à 10 revolutions)  
 170 to 320 revolutions (16 notches à 10 revolutions)



Exchange of the stickers:

After a change of the mode of operation or the adjusting range, the sticker in the inspection window of the control unit has to be exchanged.

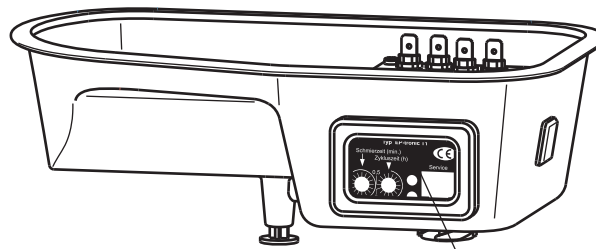

Sticker in the inspection window of the control unit

Sets of stickers can be ordered for this purpose, but the stickers can also be ordered individually.

Sticker set for BEKA-troniX1 in German  
 Order-no.: 0490000342  
 Sticker set for BEKA-troniX1 in English  
 Order-no.: 0490000343

Sticker set for EP-tronic in German  
 Order-no.: 0490000317

### 11.1.5. Optional equipment:

#### Grease level monitoring at the BEKA-troniX1 and the EP-tronic:

A capacitive proximity switch is installed into the reservoir for the electronic control of the grease level in this reservoir. It sends a signal as long as there is enough lubricant in the reservoir.

EN

#### Technical data of the proximity switch:

Operating voltage:	10 to 60 V DC
Connection method:	PNP-NO (normally open contact)
Max. current load:	250 mA
Protection class of the switch:	IP 67
Ambient temperature range:	25° C to +70° C
Connection:	4-poles, M12x1 pluggable

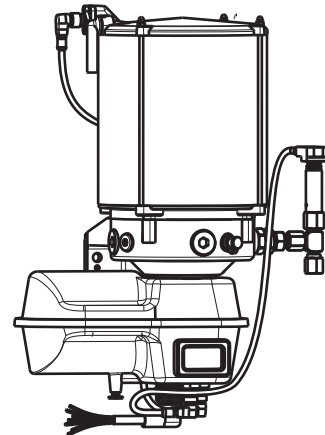

The signal is evaluated by the control unit. When there is no signal for more than 10 seconds, the control unit reports a malfunction (see signals on page 33) and switches the pump off.

The pump starts to operate again automatically with refilling of the reservoir.

#### Pressure relief valve monitoring at the BEKA-troniX1 and the EP-tronic:

With a micro switch, which is mounted at the pressure relief valve of the pump element, the operating pressure of the system can be monitored. If the pressure in the lines exceeds 280 bar, the pressure relief valve reacts.

The micro switch sends a signal to the control unit, which then switches off the pump and indicates a malfunction (see signals on page 33; terminal diagrams on page 15 and 19).

26

#### Technical data of the micro switch:

Operating voltage:	10 to 60 V DC
Contact type:	1 changeover contact
Max. current load:	I = 1,7 A
Protection class of the switch:	IP 67
Ambient temperature range:	25° C to +85° C
Connection:	cable 0.5 m, bonded, 4-poles, M12x1 pluggable

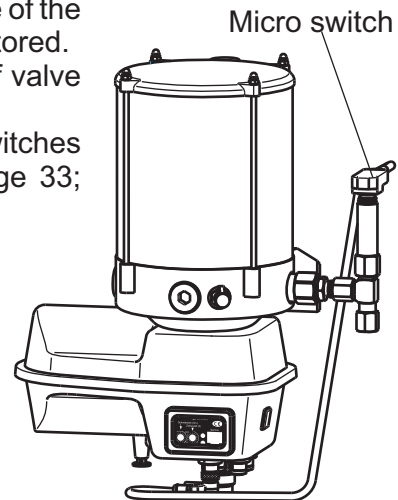

After troubleshooting, you have to start the pump by pressing the button for intermediate lubrication.

Starter release or collective fault signal at the EP-tronic:

A starter release or a collective fault signal can optionally be connected to the EP-tronic control unit.

The starter release prevents that the machine continues operating as long as there is a malfunction indicated by the control unit. In the case of a level error can a movement be blocked by an electronic signal, e.g.

After troubleshooting, you can push the button for intermediate lubrication in order to delete the error, the pump can continue operating and starts its normal sequence of functions.

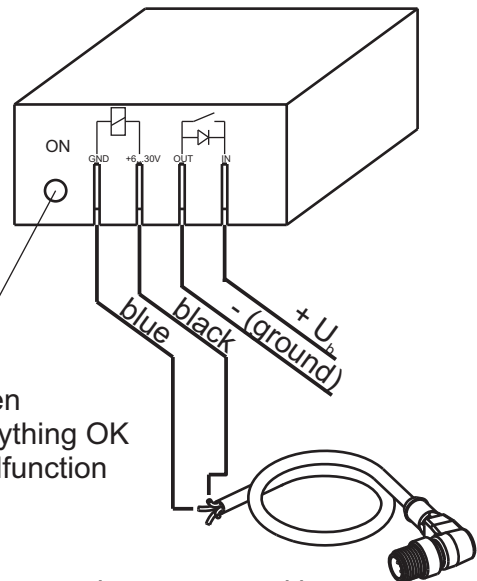

LED green  
ON: everything OK  
OFF: malfunction



The collective fault signal enables to indicate all error messages via a connected lamp or horn, e.g. The lamp or the horn generate a permanent signal (permanent glowing or tone) as long as the indicated malfunction exists. The indication is stopped automatically when the malfunction has been remedied.

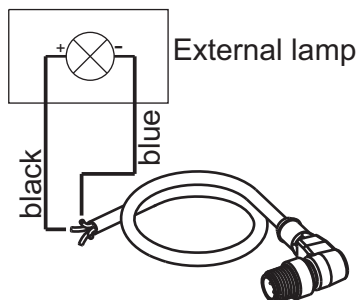

Technical data:  
Voltage:  
Output current:

12/24 V DC  
max. 0.5A

Adaption to the application conditions at EP-tronic:

For the EP-tronic control unit, there is the possibility to carry out an adaption to the application conditions. To this purpose is a switch with three notches installed into the driver's cabin of the vehicle or into the machine. You can select between "normal, light or heavy duty" adjustment.



The adjustment "normal" is the standard setting, cycle time is effected as adjusted.

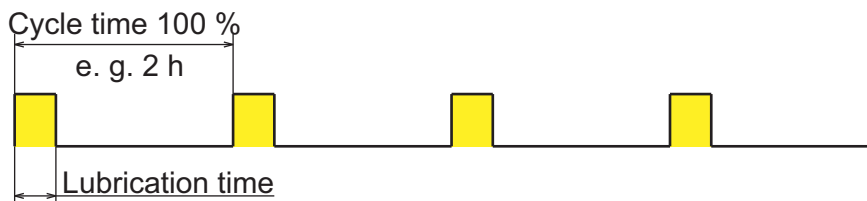

The adjustment “light” is for light load, the cycle time is increased by 25%.

EN

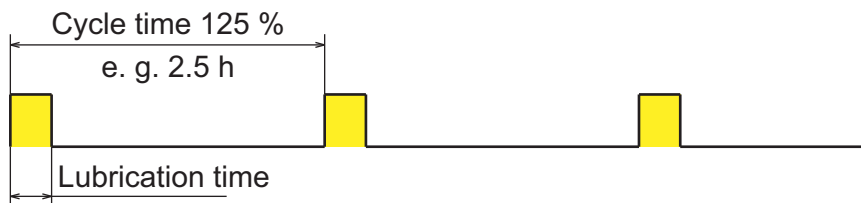

The adjustment “heavy duty” is for heavy load, the cycle time is reduced down to 25%.

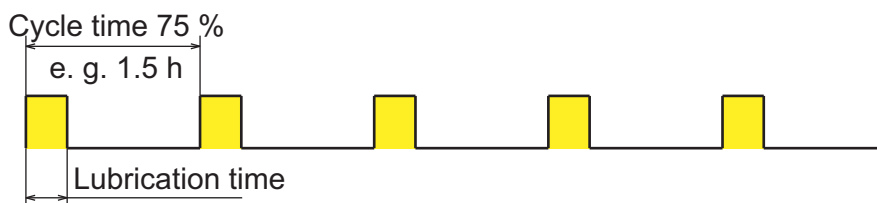

The setting has to be done during the first 30 seconds after switch on of the ignition. After a change of the settings, either the ignition has to be switched off and on again or an intermediate lubrication has to be triggered.

## 11.2. Function of the control unit EP-tronic T1:

28

### 11.2.1. Function sequence

The EP-tronic T1 is a control unit for trailers and semi-trailers and does not require a permanent current supply. It has five voltage inlets which serve for recognition of the vehicle movement. The three voltage inlets tail light, brake light and flashing alarm light serve as current source. At the control unit EP-tronic T1 is the length of the lubrication time and the cycle time adjusted. As the pump does not have a permanent current supply, it can only lubricate, if one of the three voltage connections is supplied with current. Therefore can the total lubrication time sum up of several short lubrication times.

If the lubrication time is not completed during the cycle time, the remaining lubrication time is taken over to the next cycle. The maximum to which the lubrication time can sum up is the double of it.

If there is no voltage recognized at none of the five voltage inlets for more than half an hour, the cycle time is stopped. The control unit assumes that the vehicle is no longer in motion.

The total lubrication time sums up of several short ones:

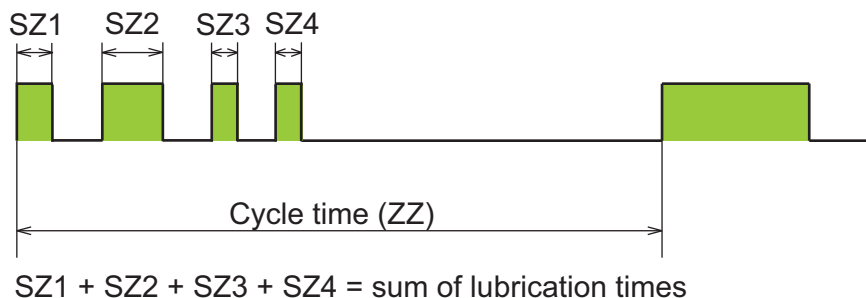

11.2.2.Extras:

Adjustment of the adjusting ranges:

The adjusting ranges can be changed by means of the diagnostic software BEKA-DiSys. All adjusting ranges for the lubrication time can be combined with all cycle time ranges.

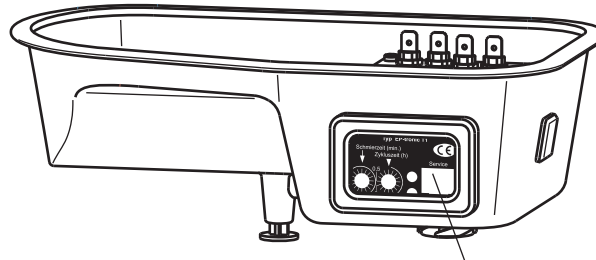

Adjusting ranges:

Connection of the system diagnosis

Lubrication times:

- 1 to 16 min. (16 notches à 1 min.)
- 2 to 32 min. (16 notches à 2 min.)
- 2 to 32 sec. (16 notches à 2 sec.)

Cycle times:

- 0,5 to 8 h (16 notches à 0,5 h)
- 2 to 32 min. (16 notches à 2 min.)
- 2 to 32 h (16 notches à 2 h)

Exchange of the stickers:

After a change of the mode of operation or the adjusting range, the sticker in the inspection window of the control unit has to be exchanged.

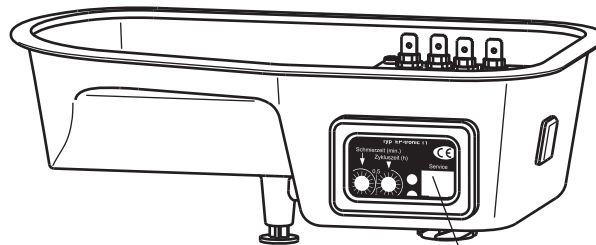

Sticker in the inspection window of the control unit

Labels can be ordered in German language with various lubrication and cycle time combinations:

Lubrication time		Cycle time		
		0.5 h to 8 h	2 min. to 32 min.	2 h to 32 h
I	1 min. to 16 min.	0490030325	0490030326	0490030327
II	2 min. to 32 min.	0490030328	0490030329	0490030330
III	2 sec. to 32 sec.	0490030331	0490030332	0490030333

Other languages are available on request!

11.3. Function sequence of the control unit EP-T2:

The control unit EP-T2 limits the duration of lubrication.

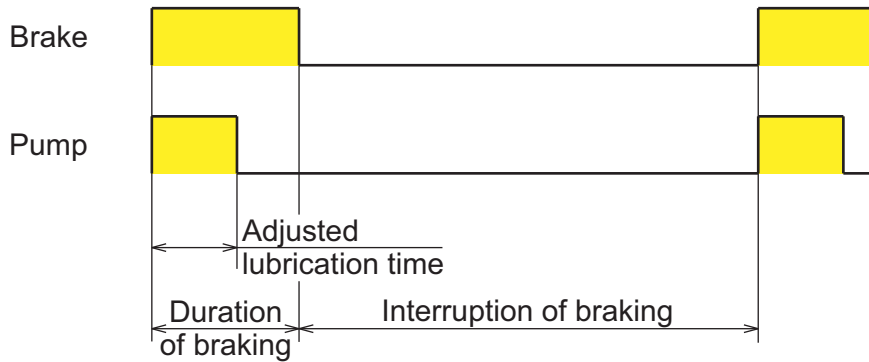

As the brake light serves as current supply of the central lubrication pump, the pump can only deliver lubricant, if the driver brakes.

Lubrication starts with each braking. After the adjusted lubrication time is the pump switched off, even if the brake process takes longer. If braking is finished before the lubrication time is over, lubrication is interrupted and starts again from the beginning with the next braking.

Short interruptions of the brake process of less than 1 sec. are ignored by the control device.

30

Braking with short interruptions:

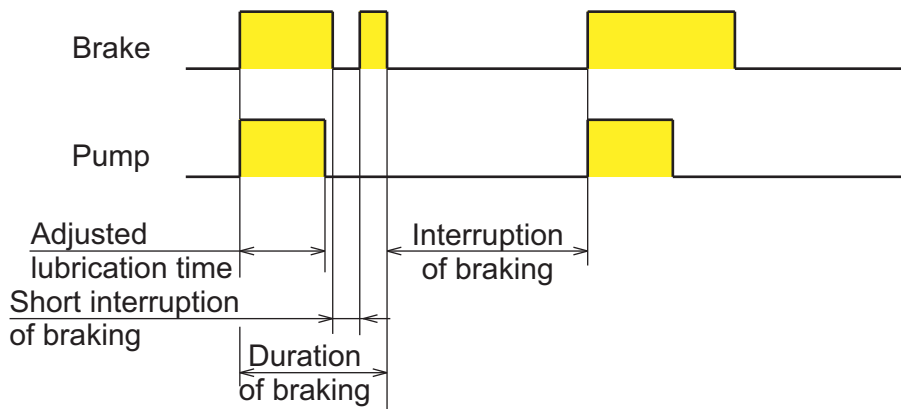

Braking shorter than the lubrication time:

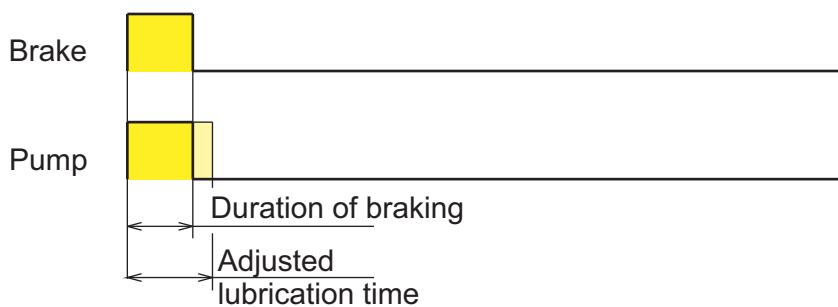

## 12. Adjustment of the control units:

### 12.1. Adjustment of the parameters:

The cycle time and lubrication time, the number of strokes and the number of revolutions can be set by means of graduating switches in the inspection window of the control unit.



For the adjustment, remove the red frame at the pump's motor housing, using a flat screwdriver, loosen the four Philips screws and remove the transparent protection cover. The cycle time and lubrication time can be adjusted with a flat screwdriver.

**Attention!**

If the cover plate is not replaced properly, water may enter the control unit and damage it. Your guarantee expires in this case.

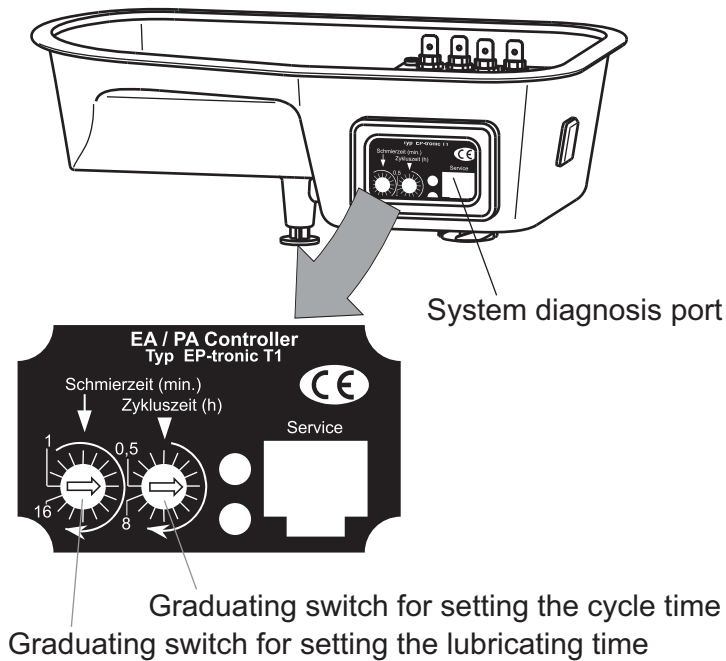

### 13. Filling of the pump:

#### 13.1. Standard filling via lubrication nipple with manual or pneumatic grease gun:

:

EN

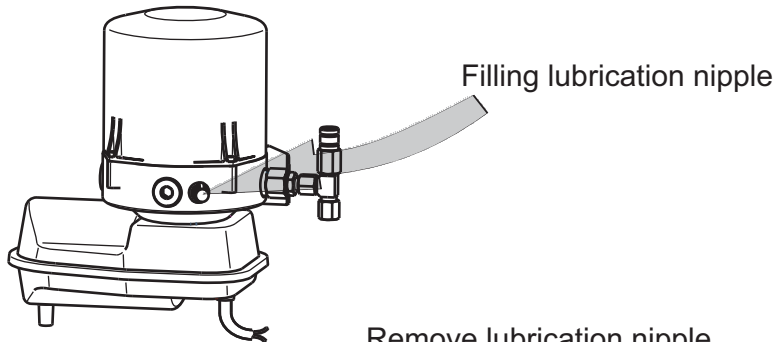

#### 13.2. Filling via filler coupling:

Remove lubrication nipple and replace it by a coupling plug for grease  
article-no.: 2159 0061 006

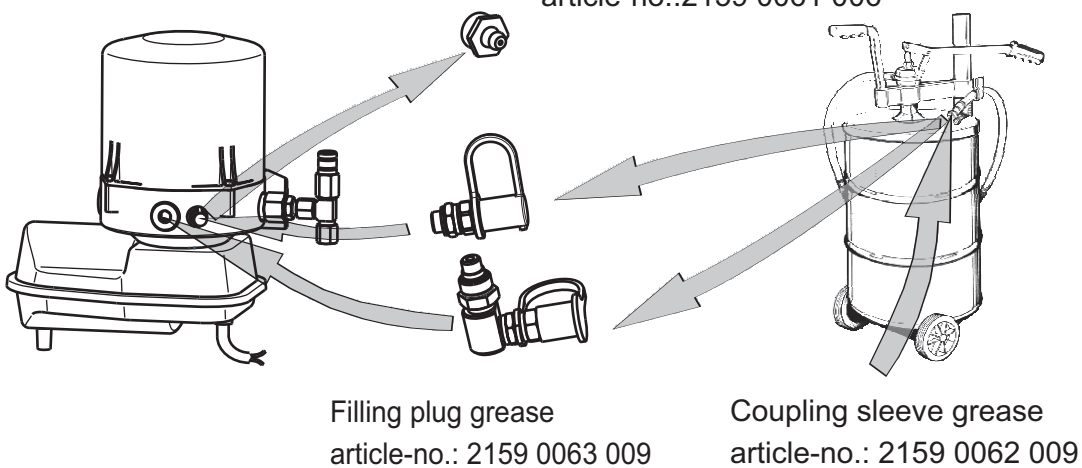

32

#### 13.3. Filling via filling press:

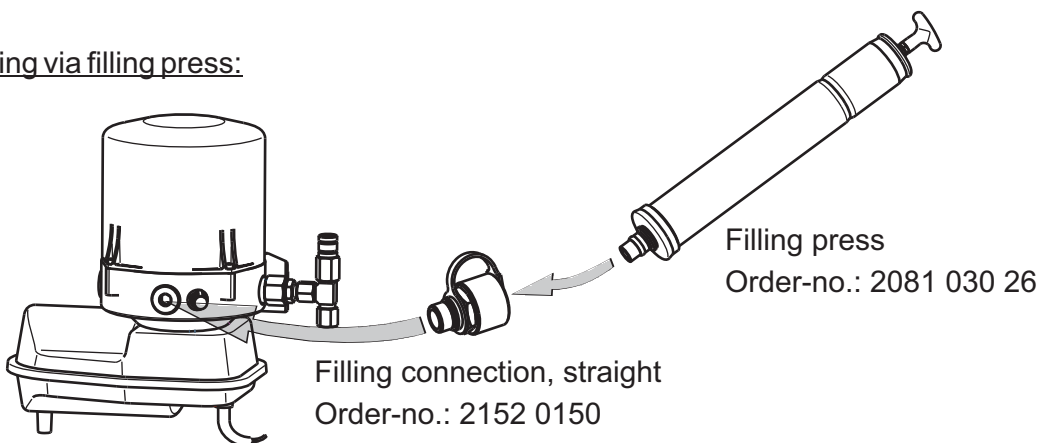

**Attention!**

Utmost cleanness is essential for this work!  
Only fill in clean lubricant!

**Note!**

The service life of the pump elements highly depends on the quality (impurities) of the used lubricant.



## 14. Signals:

The pump's functions are indicated by two LEDs (green/red) in the inspection window of the motor housing of the pump, whereas the red LED always indicates an error in the program sequence.

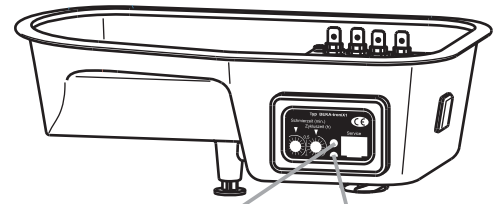

Red LED error indicator  
Green LED function indicator



Signals	Function	BEKA-tronIX1	EP-tronic	EP-tronic T1
	Standby indicator	X	X	X
	Lubrication sequence	X	X	X
	Grease level error	X	X	
	Excess pressure error	X	X	
	Revolution error	X	X	
	Stroke error		X	
	Memory error	X	X	
	Test lubrication	X	X	X

In order to activate permanent lubrication for service purposes in the mode “time control”, the lubrication time has to be set on a higher value than the cycle time.

## 15. Ventilation of the pump:

If the lubricant reservoir has been emptied completely by mistake, it may be necessary to ventilate the pump.

To do so, proceed as follows:

- EN**
1. Unscrew main line from pump outlet.
  2. Trigger additional lubrication pulse until lubricant comes out of the pump outlet without air inclusions.
  3. Reconnect main line.
  4. Trigger additional lubrication pulse.

## 16. Service and maintenance:

All components of the grease central lubrication pump are maintenance-free.  
Cleaning in washing plants or with steam jet devices (minimum distance 40 cm) is permitted.



Ensure that the current supply is deactivated (ignition off) before doing maintenance works at the pump. Clean soiled or contaminated surfaces before the maintenance work and wear protective cloths if necessary.

34

Nevertheless should a visual inspection be carried out in regular intervals:

- Check the level
- Check the condition of the electrical lines (electric main, connection cables to the progressive distributor, etc.)
- Check the electrical connections (connectors)
- Check the perfect function of the control unit by triggering an intermediate lubrication
- Only replace defective fuses by equivalent ones
- Check all components for leakages or damages every four weeks.

### **Attention!**

All further works may only be carried out by the staff of BEKA or by staff trained by BEKA.

## 17. Disposal:

### **Note!**

The waste disposal advice of the well fluid manufacturer must be heeded when changing lubricant!

Observe the regional valid regulations concerning the disposal of the grease lubrication pump.

### 18. Spare parts drawing:

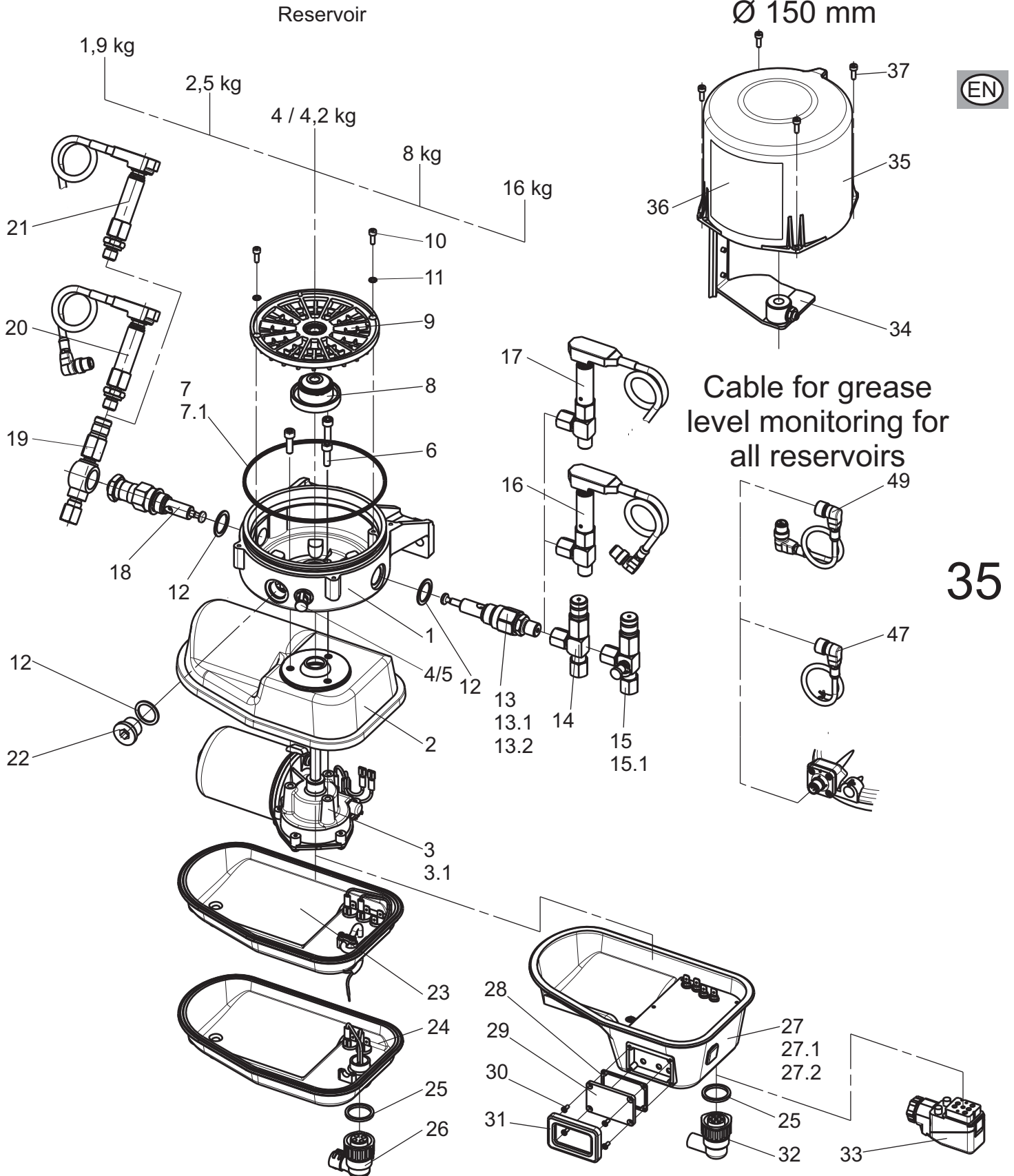

BAL\_2152\_EP1\_Central grease lubrication pump\_0816\_EN EDV-Nr. 1090200430

2,5 kg reservoir  
Ø 150 mm

4 resp. 4,2 kg reservoir  
Ø 180 mm

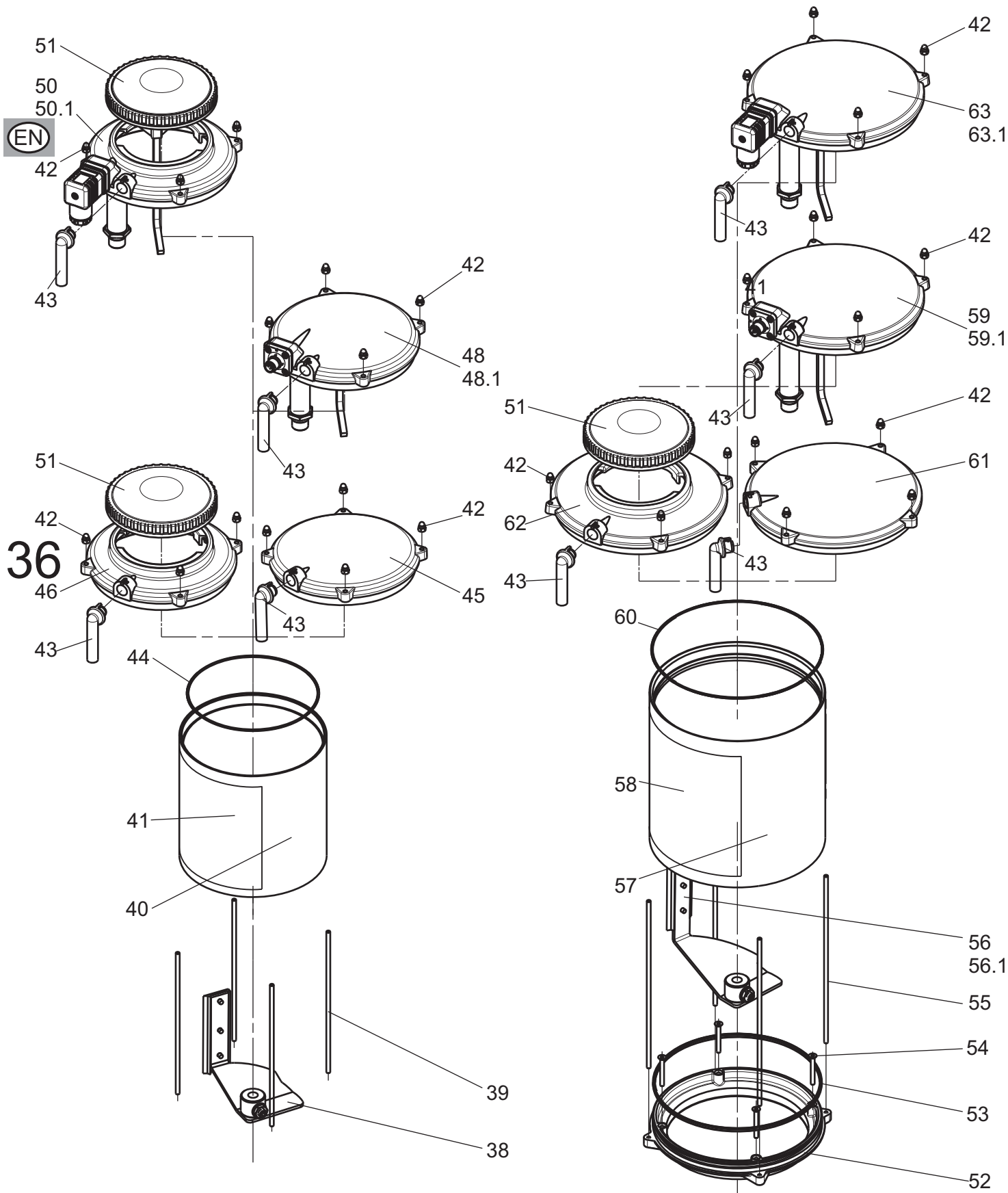

8 kg reservoir,  
Ø 226 mm

16 kg reservoir,  
Ø 226 mm

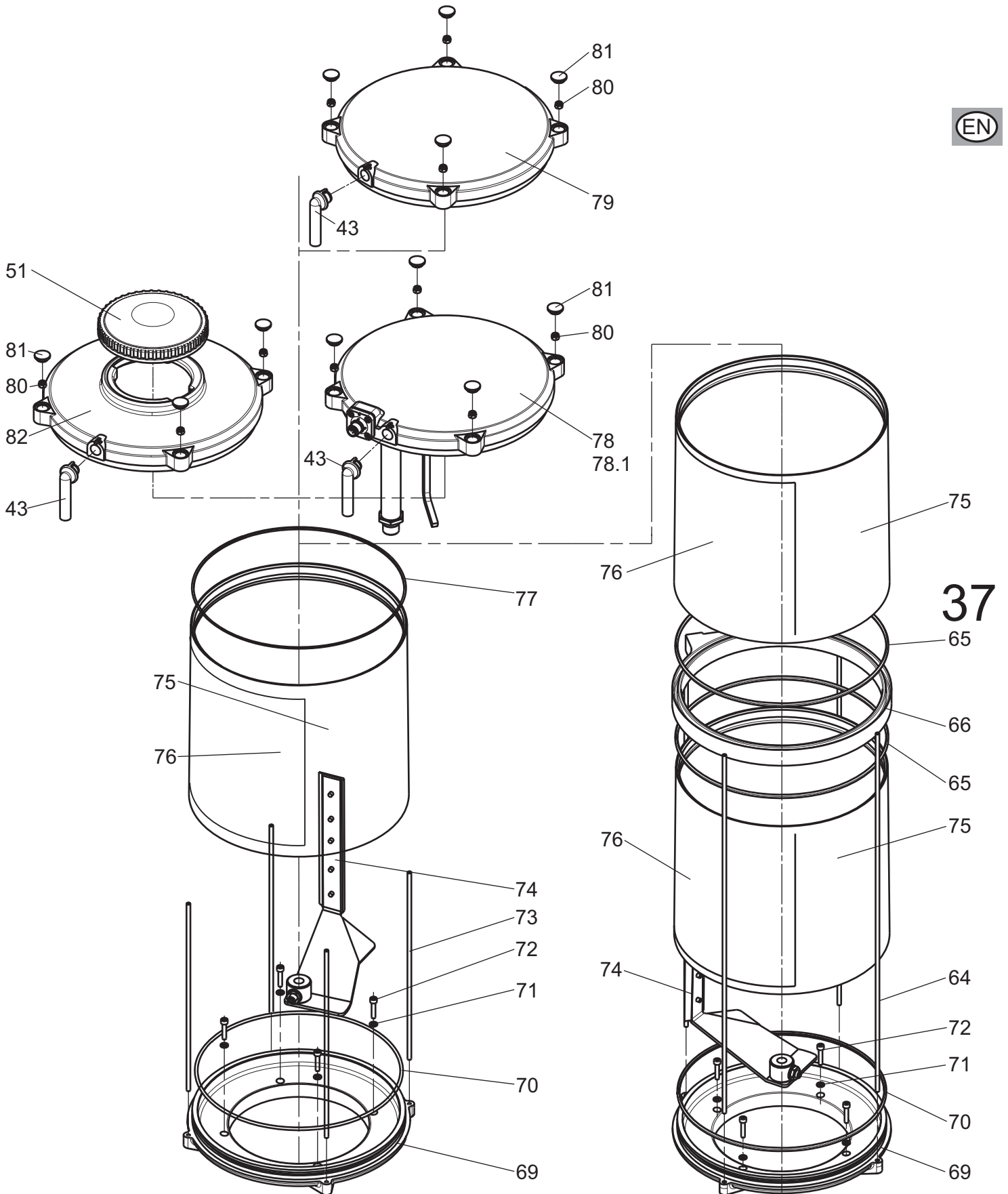

BAL\_2152\_EP1\_Central grease lubrication pump\_0816\_EN EDV-Nr. 1090200430

## 19. Spare parts list:

Pos.	Qty.	Designation	Item number
1	1	Pump housing	21520010
2	1	Motor housing above	FMZ00437-00
3	1	Direct current gear motor 12 V	00503100001169
3.1	1	Direct current gear motor 24 V	00503100000496
4	1	Hydraulic form grease nipple A1 G1/4"	097141201211
5	1	Cap for hydraulic form grease nipple	1004010021
6	3	Cylinder screw with internal hexagon M6x25	090091204021
7	1	O-ring 135x3.5 for 1.9 kg reservoir	09037710210141
7.1	1	O-ring 135x3 for 2.5 to 8 kg reservoir	09037710152141
8	1	Eccentric unit	21520020
9	1	Perforated base plate	21520040
10	2	Cylinder screw with internal hexagon M4x12	090091200321
11	2	Spring ring B4	090012800411
12	0-3	Cu-sealing ring 27x20x1.5	090760300811
13	0-3	Pump element PE-60 without DBV incl. sealing ring	2152990670003
13.1	0-3	Pump element PE-120 without DBV incl. sealing ring	2152990610103
13.2	0-3	Pump element PE-170 without DBV incl. sealing ring	2152990690100
14	0-3	Pressure relief valve for PE-60, PE-120 a. PE-170	21520060
15	0-3	Pressure relief valve right for PE-60 to PE-170	21520076
15.1	0-3	with lubrication nipple without connecting piece Pressure relief valve left for PE-60 to PE-170	21520068
16	0-3	with lubrication nipple without connecting piece Pressure relief valve for PE-60 to PE-170	215299115
17	0-3	with micro switch for BEKA-troniX1 and EP-tronic Pressure relief valve for PE-60 to PE-170	215299100
18	0-3	with micro switch without plug M12x1 Pump element PE-120 V without pressure relief valve incl. sealing ring	2152990630014
19	0-3	Pressure relief valve for PE-120 V	21520063
20	0-3	Pressure relief valve for PE-120 V with micro switch for BEKA-troniX1 and EP-tronic	215299116
21	0-3	Pressure relief valve for PE-120 V with micro switch without plug	2152990610028
22	0-3	Screw plug M20x1.5	090090800850
23	1	Motor housing below with cable, 10 m	21520103
24	1	Motor housing below with bayonet connector without connecting cable	21520108
25	1	Sealing for bayonet connector	08100192
26	1	4-pole bayonet connector without cable	1000913356
27	1	Motor housing below with integrated control unit BEKA-troniX1, EP-tronic, EP-tronic T1 or EP-T2	see ordering key
27.1	1	Motor housing below with integrated PSU 115 V AC to 24 V DC	21520113
27.2	1	Motor housing below with integrated PSU 230 V AC to 24 V DC	21520114
28	1	Sealing for inspection window at motor housing below	080100116
29	1	Inspection window for motor housing below	FMZ00439-00
30	4	Slotted countersunk head screw M3x8 for inspection window	09i07046101121

EN

38

Pos.	Qty.	Designation	Item number
31	1	Frame for inspection window, red	FMZ00442-000 001
32	1	7-pole bayonet connector for integrated control units	1000912932
33	1	7-pole Hirschmann connector for FKGGM-EP with PSU	100091211
1.9 kg lubricant reservoir:			
34	1	Agitator blade f. 1.9 kg reservoir w. fastening material	21520053
35	1	Transparent reservoir 1.9 kg	FMZ00460-00
36	1	Filling level sticker for 1.9 kg reservoir BEKA-MAX	0490030103
37	4	Socket head cap screw M4x12, Tuflok coated	0900912003232
2.5 kg lubricant reservoir (outside dia. 150 mm):			
38	1	Agitator blade f. 2.5 kg reservoir w. fastening material	21520050
39	4	Connecting rod for 2.5 kg lubricant reservoir	0802000345
40	1	Transparent reservoir 2.5 kg (outside dia. 150 mm)	F0396/03-00
41	1	Filling level sticker f. 2.5 kg reservoir, model for grease, with BEKA-MAX-Logo	0490030049
42	1	Head nut M4, DIN 986	090098600113
43	1	Ventilation tube f. 2.5 kg reservoir	FMZ00486-00
44	1	O-ring 130,07x1,78 f. reservoir cover f. 2.5 kg reservoirs	09037710057141
45	1	Reservoir cover 2,5 kg incl. O-ring, head nut and ventilation pipe	21520380
46	1	Reservoir cover 2,5 kg with filling cover, incl. O-ring, head nut and ventilation pipe	21520381
47	1	Cable with plug-type connection M12x1 angled with free end, 5 m, for connection of level monitoring	1000912997
48	1	Reservoir cover for 2,5 kg with level monitoring min. with plug-type connect. M12x1, standard vers., with or without cable, incl. O-ring, cap nut and ventilation pipe	see order key
48.1	1	Reservoir cap 2,5 kg with level monitoring min. with plug connection M12x1, low temp. version with or without connection cable, incl. O-ring, head nut a. ventilation pipe	see order key
49	1	Cable with plug-in connector M12x1 angular on both sides, length 0,6 m, for connection of the level monitoring to the integrated control units BEKA-troniX1 and EP-tronic	1000912998
50	1	Reservoir cap 2,5 kg with filling cover with level monitoring min. w. cubic plug, 10-60 V DC with or without connection, incl. O-ring, head nut a. ventilation pipe	see order key
50.1	1	Reservoir cover 2,5 kg with filling cover., with grease level monitoring min. w. cubic plug, 90-250 V AC, with NO, NC contact, with or without connection piece incl. O-ring, head nut a. ventilation pipe	see order key
51	1	Screw cap	04500020
4 resp. 4,2 kg lubricant reservoir (outside dia. 180 mm):			
52	1	Intermediate flange 4 resp. 4.2 kg (model for grease)	FMZ00426-00
53	1	O-ring 165x3 (model for grease)	09037710062141
54	4	Countersunk screw M4x35 (model for grease)	090799100111
55	4	Connecting rod for 4 kg lubricant reservoir	0802000349
56	1	Agitator blade for 4 kg reservoir incl. fastening material	21520051
57	1	Transparent reservoir 4 resp. 4.2 kg and 8 kg, 2 parts (outside Ø 180 mm)	F0395/17-00



39



40

Pos.	Qty.	Designation	Item number
58	1	Filling level sticker for 4 resp 4.2 kg reservoir model for grease with BEKA-MAX-Logo	0490030219
59	1	Reservoir cover 4 kg with level monitoring min. with plug connection M12x1, standard version with order key or w/o connection cable, incl. O-ring, head nut a. ventilation	see
59.1	1	Reservoir cover 4 kg mit level monitoring min. with plug connection M12x1, low temp. version with o. without connection cable, incl. O-ring, head nut a. ventilation	see order key
60	1	O-ring 160x2.5 for 4 resp. 4.2 kg and 8 kg reservoir	09037710141141
61	1	Reservoir cover 4 bzw. 4,2 kg and 8 kg, incl. O-ring, head nut a. ventilation	21520386
62		Reservoir cover 4 bzw. 4,2 kg and 8 kg with screw cover incl. O-ring and ventilation pipe	21520387
63	1	Reservoir cover 4 or 4,2 kg with level monitoring with cubic plug 10-60 V DC, with or without connection part, incl. O-ring, head nut a. ventilation	see order key
63.1	1	Reservoir cover 4 bzw. 4,2 kg with level monitoring with cubic plug 90-250 V AC, with NO or NC with or without connection cable, incl. O-ring, head nut a. ventilation	see order key
16 kg lubricant reservoir (outside-Ø 226 mm)			
64	4	Connecting rod for 16 kg reservoir	0802000713
65	1-2	O-ring Ø215,49 x Ø3,53	09037710274141
66	1	Intermediate ring 8 for 16 kg	FWZ05106-00
8 kg lubricant reservoir, 1 part (Outside Ø 226 mm)			
69	1	Intermediate flange for 8 kg reservoir, 1-part	F0396/39-07
70	1	O-ring 209.14x3.53	09037710272141
71	4	CU-sealing ring 4x8x1	090760301211
72	4	Socket head cap screw M4x20	090091201423
73	4	Connecting rod for 8 kg reservoir, 1 part	0802000351
74	1	Agitator blade for 8 kg reservoir, 1 part incl. fastening material	21520055
75	1	Transparent reservoir 8 kg, 1 part (dia. 226 mm)	FMZ00502-00
76	1	Filling level sticker for reservoir 8 kg, 1 part	0490030389
77	1	O-ring 180x3	09037710154141
78	1	Reservoir cover 8 or 16 kg with level monitoring min. with plug connection M12x1, standard version, with o. without connect., incl. O-ring, head nut a. ventilation	see order key
78.1	1	Reservoir cover 8 bzw. 16 kg with level monitoring min. with plug connection M12x1, low temp. version with o. without connect., incl. O-ring, head nut a. ventilation	see order key
79	1	Reservoir cover for 8 kg reservoir incl. O-ring and ventilation pipe	21520392
80	4	Hexagon nut M4, self locking	090098500233
81	4	Cover for connecting rods at 8 kg reservoirs	1004010166
82	1	Reservoir cover for 8 kg reservoirs with screw cover, incl. O-ring, ventilation pipe	21520394



**20. Order key of level monitoring:**  
integrated in reservoir cover

Type: \_\_\_\_\_ 4458 . 1 . 1 . 1 . 1 . 00



Temperature range	Standard version up to -20°C			
Operat. voltage	10 - 60 V DC		90 - 250 V AC	
Version	min.	min. and max.	min.	min. and max.
Code	1	2	3	4
Temperature range	Low temperature version to -40°C			
Operating voltage	12 - 30 V DC			
Version	min.		min. and max.	
Code	5		6	

Res. size	2 and 2,5 kg	4 and 4,2 kg	8 kg
Code	1	2	3

Connection type	M12x1 (only at 10-60 V DC)			
Connection cable	w/o	M12x1 bush 90° M12x1 plug 90° 0,6 m long		M12x1 bush 90° free cable ending 5 m long
	Code	1	2*	3
Connection type	Cubic plug acc. to DIN 43650 w/o cable			
Cable connection	only plug socket	Socket w. plug	only plug socket	Socket w. plug
Switch type	NO contact		NC contact	
Code	4	5	6	7

Filling cover	w/o	w
Code	1	2

Special version	w/o
Code	00

41

\* Version for connection at integrated control unit (only at min. 10-60 V DC)

## 20. Order key for the control units:

### 20.1. Control unit EP-tronic:

**Type** \_\_\_\_\_ 2157 . 90 . 10 . 0 . A . 1 . 00

EN

Connector version	
with bayonet connector	10

Additional equipment	
not connected to control unit	0
connected to control unit	
system pressure P <sub>max.</sub>	1
grease level monitoring	2
system pressure monitoring and grease level monitoring	3

Parameter	Cycle time		
	0.5 to 8 h	2 to 32 min.	2 to 32 h
I 1 to 16 min.	1	A	J
II 2 to 32 min.	2	B	K
III 2 to 32 sec.	3	C	L
Strokes			
I 1 to 16 strokes	4	D	M
II 17 to 32 strokes	5	E	N
III 33 to 48 strokes	6	F	O
Pump revolutions			
I 1 to 16	7	G	P
II 10 to 160	8	H	Q
III 170 to 320	9	I	R

with collective fault signal (stat. error) (Standard)	1
with starter release	2

Special models	00
----------------	----

42

**20.2. Control unit EP-tronic T1:**

<b>Type</b>		2183 . 90 . 10 . X . X . XXXX		
Connector version				
with bayonet connector	10			
Lubrication time range		Cycle time range		
		0.5 h to 8 h	2 min. to 32 min.	2 h to 32 h
I	1 min. to 16 min.	1	A	J
II	2 min. to 32 min.	2	B	K
III	2 sec. to 32 sec.	3	C	L
Button for intermediate lubrication		without	with	
Code		0	1	
Special models		without		
Code		0000		



**20.1. Control unit BEKA-troniX1:**

<b>Type</b>		2175 . 90 . 10 . 0 . A . 000		
Connector version				
with bayonet connector	10			
Additional equipment				
without connection for additional equipment		0		
with grease level monitoring		1		
with system pressure monitoring		2		
with grease level monitoring and system pressure monitoring		3		
with contact plugs (not activated)		4		
Parameter		Cycle time		
Lubrication time		0.5 to 8 h	2 to 32 min.	2 to 32 h
I	1 to 16 min.	1	A	J
II	2 to 32 min.	2	B	K
III	2 to 32 sec.	3	C	L
Revolutions of the pump				
I	1 to 16	7	G	P
II	10 to 160	8	H	Q
III	170 to 320	9	I	R
Special models		000		

20.4. Control unit EP-T2:

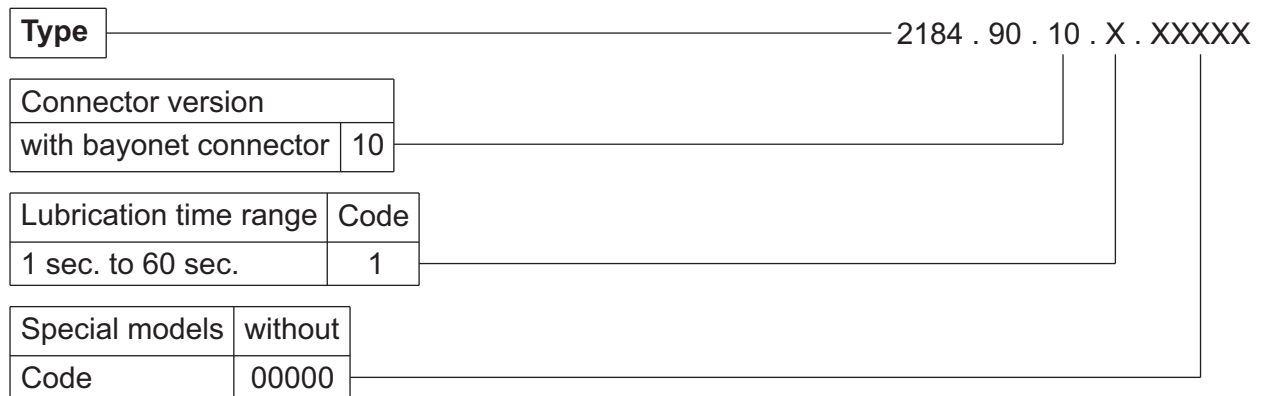

EN

## 21. Malfunction - Cause - Remedy:

Malfunction	Cause	Remedy
<ul style="list-style-type: none"> <li>- Pump does not operate</li> </ul>	<ul style="list-style-type: none"> <li>- Fuse of unit blown</li> <li>- Integrated electronic control defective</li> <li>- Electrical cable broken</li> <li>- Pump defective</li> <li>- Pump element not nested</li> </ul>	<ul style="list-style-type: none"> <li>- Replace fuse</li> <li>- Replace integrated control</li> <li>- Renew electrical cable</li> <li>- Replace the pump</li> <li>- Renew pump element</li> </ul>
<ul style="list-style-type: none"> <li>- Pump operates, but does not supply lubricant</li> </ul>	<ul style="list-style-type: none"> <li>- Air in the feed piston</li> <li>- Filling level below minimum</li> <li>- Defective pump element</li> </ul>	<ul style="list-style-type: none"> <li>- Ventilate the pump</li> <li>- Re-fill the reservoir</li> <li>- Renew pump element</li> </ul>
<ul style="list-style-type: none"> <li>- No grease collar at all lubrication points</li> </ul>	<ul style="list-style-type: none"> <li>- Pump does not operate</li> <li>- Cycle time too long</li> <li>- Lubrication time too short</li> <li>- Number of strokes too low</li> <li>- Number of rotation too low</li> <li>- Pump element PE-120 V adjusted too low</li> <li>- System blocked</li> </ul>	<ul style="list-style-type: none"> <li>- See „Pump does not operate“</li> <li>- Reduce cycle time</li> <li>- Increase lubrication time</li> <li>- Increase number of strokes</li> <li>- Increase number of rotations</li> <li>- Adjust pump element</li> <li>- See „Leakage of grease at the pressure relief valve“</li> </ul>
<ul style="list-style-type: none"> <li>- No grease collar at several lubrication points</li> </ul>	<ul style="list-style-type: none"> <li>- Feed pipes for secondary distributors burst or leaky</li> <li>- Fitting leaky</li> </ul>	<ul style="list-style-type: none"> <li>- Renew the pipe</li> <li>- Re-tighten or renew the fitting</li> </ul>
<ul style="list-style-type: none"> <li>- No grease collar at one lubrication point</li> </ul>	<ul style="list-style-type: none"> <li>- Appropriate lubrication line burst or leaky</li> <li>- Fitting leaky</li> </ul>	<ul style="list-style-type: none"> <li>- Renew the pipe</li> <li>- Re-tighten or renew the fitting</li> </ul>
<ul style="list-style-type: none"> <li>- Reduced pump speed</li> </ul>	<ul style="list-style-type: none"> <li>- High pressure in the system</li> <li>- Low ambient temperature</li> </ul>	<ul style="list-style-type: none"> <li>- Check system / bearing points</li> <li>- Not defectiveness (1 or 2 intermediate lubrication cycles might be useful)</li> </ul>



EN

46

<b>Malfunction</b>	<b>Cause</b>	<b>Remedy</b>
<ul style="list-style-type: none"> <li>- Leakage of grease at the pressure relief valve</li> </ul>	<ul style="list-style-type: none"> <li>- Excessive pressure in the system</li> <li>- Progressive distributor blocked</li> <li>- System blocked</li> <li>- Defective valve spring</li> </ul>	<ul style="list-style-type: none"> <li>- Check the system</li> <li>- Replace distributor</li> <li>- Repair blocked bearing point</li> <li>- Renew the pressure relief valve</li> </ul>
<ul style="list-style-type: none"> <li>- The red indicator pin at the malfunction indicator of the pump element is visible</li> </ul>	<ul style="list-style-type: none"> <li>- Excessive system pressure</li> </ul>	<ul style="list-style-type: none"> <li>- See „Leakage of grease at the pressure relief valve“</li> </ul>
<ul style="list-style-type: none"> <li>- The LEDs in the inspection window of the control flash</li> </ul>	<ul style="list-style-type: none"> <li>- Pump lubricates</li> <li>- Grease level error</li> <li>- Excessive pressure error</li> <li>- Speed error</li> <li>- Stroke error</li> <li>- CPU/memory error</li> </ul>	<ul style="list-style-type: none"> <li>- No error (see signals)</li> <li>- Fill reservoir</li> <li>- Check the system and repair it, if necessary</li> <li>- Check the system and repair it, if necessary</li> <li>- If there is no defectiveness, activate intermediate lubrication once or twice</li> <li>- <del>Exchange the control unit</del></li> </ul>
<ul style="list-style-type: none"> <li>- Level error, although the reservoir is filled with lubricant</li> </ul>	<ul style="list-style-type: none"> <li>- Capacitive proximity switch in the reservoir defective</li> <li>- Cable of the level monitoring defective</li> </ul>	<ul style="list-style-type: none"> <li>- Send the lubricant reservoir with level monitoring in for being repaired</li> <li>- <del>Exchange the cable</del></li> </ul>
<ul style="list-style-type: none"> <li>- Level error although there is no level monitoring in the pump</li> </ul>	<ul style="list-style-type: none"> <li>- Level monitoring activated in the control unit</li> </ul>	<ul style="list-style-type: none"> <li>- Deactivate level monitoring in the control unit with the system diagnosis software BEKA-DiSys</li> </ul>
<ul style="list-style-type: none"> <li>- The pump function (pump operating time or cycle time) does not correspond to the values adjusted in the inspection window of the control unit</li> </ul>	<ul style="list-style-type: none"> <li>- The operating mode or the adjustment range of the control has been changed, but the sticker in the inspection window not</li> </ul>	<ul style="list-style-type: none"> <li>- Make a diagnosis with the diagnosis software</li> <li>- BEKA-DiSys</li> <li>- Adapt the adjustment to the sticker in the inspection window or exchange the sticker</li> </ul>

For your notes:



# BEKA

BAIER + KÖPPEL  
BEETHOVENSTR: 14  
91257 PEGNITZ / BAYERN

fon +49 9241 729-0  
fax +49 9241 729-50

P.O.BOX 1320  
91253 PEGNITZ / BAVARIA

e-mail [beka@beka-lube.de](mailto:beka@beka-lube.de)  
[beka@beka-max.de](mailto:beka@beka-max.de)

web [www.beka-lube.de](http://www.beka-lube.de)



# 46

## Other products from our range of supplies:

- Gear pumps
- Multiple line oil pumps
- Multiple line grease pumps
- Single line central lubrication systems
- Dual line central lubrication systems
- Oil circulation central lubrication systems
- Oil/air and spray lubrication
- Wheel flange central lubrication systems
- Rolling mill central lubrication systems
- Commercial vehicle lubrication
- Progressive distributors
- Control and monitoring units